

ELEMENT 4 - EXTRA CLASS QUESTION POOL

Valid July 1, 2008 through June 30, 2012

741 questions total

SUBELEMENT E1 -- COMMISSION'S RULES [6 Exam Questions -- 6 Groups]

E1A Operating Standards: frequency privileges for Extra Class amateurs; emission standards; automatic message forwarding; frequency sharing; FCC license actions; stations aboard ships or aircraft

E1A01 (D) [97.301, 97.305]

When using a transceiver that displays the carrier frequency of phone signals, which of the following displayed frequencies will result in a normal USB emission being within the band?

D. 3 kHz below the upper band edge

~~

E1A02 (D) [97.301, 97.305]

When using a transceiver that displays the carrier frequency of phone signals, which of the following displayed frequencies will result in a normal LSB emission being within the band?

D. 3 kHz above the lower band edge

~~

E1A03 (C) [97.301, 97.305]

With your transceiver displaying the carrier frequency of phone signals, you hear a DX station's CQ on 14.349 MHz USB. Is it legal to return the call using upper sideband on the same frequency?

C. No, my sidebands will extend beyond the band edge

~~

E1A04 (C) [97.301, 97.305]

With your transceiver displaying the carrier frequency of phone signals, you hear a DX station's CQ on 3.601 MHz LSB. Is it legal to return the call using lower sideband on the same frequency?

C. No, my sidebands will extend beyond the edge of the phone band segment

~~

E1A05 (C) [97.305]

Which is the only amateur band that does not permit the transmission of phone or image emissions?

C. 30 meters

~~

E1A06 (B) [97.303]

What is the maximum power output permitted on the 60 meter band?

B. 50 watts PEP effective radiated power relative to a dipole

~~

E1A07 (D) [97.303]

What is the only amateur band where transmission on specific channels rather than a range of frequencies is permitted?

D. 60 meter band

~~

E1A08 (C) [97.303]

What is the only emission type permitted to be transmitted on the 60 meter band by an amateur station?

C. Single sideband, upper sideband only

~~

E1A09 (A) [97.301]

Which frequency bands contain at least one segment authorized only to control operators holding an Amateur Extra Class operator license?

A. 80/75, 40, 20 and 15 meters

~~

E1A10 (B) [97.219]

If a station in a message forwarding system inadvertently forwards a message that is in violation of FCC rules, who is primarily accountable for the rules violation?

B. The control operator of the originating station

~~

E1A11 (A) [97.219]

What is the first action you should take if your digital message forwarding station inadvertently forwards a communication that violates FCC rules?

A. Discontinue forwarding the communication as soon as you become aware of it

~~

E1A12 (A) [97.11]

If an amateur station is installed on board a ship or aircraft, what condition must be met before the station is operated?

A. Its operation must be approved by the master of the ship or the pilot in command of the aircraft

~~

E1A13 (B) [97.5]

When a US-registered vessel is in international waters, what type of FCC-issued license or permit is required to transmit amateur communications from an on-board amateur transmitter?

B. Any amateur license or reciprocal permit for alien amateur licensee

~~

E1B Station restrictions and special operations: restrictions on station location; general operating restrictions, spurious emissions, control operator reimbursement; antenna structure restrictions; RACES operations

E1B01 (D) [97.3]

Which of the following constitutes a spurious emission?

D. An emission outside its necessary bandwidth that can be reduced or eliminated without affecting the information transmitted

~~

E1B02 (D) [97.13]

Which of the following factors might cause the physical location of an amateur station apparatus or antenna structure to be restricted?

D. The location is significant to our environment, American history, architecture, or culture.

~~

E1B03 (A) [97.13]

Within what distance must an amateur station protect an FCC monitoring facility from harmful interference?

A. 1 mile

~~

E1B04 (C) [97.13, 1.1305-1.1319]

What must be done before placing an amateur station within an officially designated wilderness area or wildlife preserve, or an area listed in the National Register of Historical Places?

C. An Environmental Assessment must be submitted to the FCC

~~

E1B05 (B) [97.15]

What height restrictions apply to an amateur station antenna structure not close to a public use airport unless the FAA is notified and it is registered with the FCC?

B. It must be no higher than 200 feet above ground level at its site

~~

E1B06 (A) [97.15]

Which of the following additional rules apply if you are installing an amateur station antenna at a site within 20,000 feet of a public use airport?

A. You may have to notify the Federal Aviation Administration and register it with the FCC

~~

E1B07 (A) [97.15]

Whose approval is required before erecting an amateur station antenna located at or near a public use airport if the antenna would exceed a certain height depending upon the antenna's distance from the nearest active runway?

A. The FAA must be notified and it must be registered with the FCC

~~

E1B08 (D) [97.121]

On what frequencies may the operation of an amateur station be restricted if its emissions cause interference to the reception of a domestic broadcast station on a receiver of good engineering design?

D. On the interfering amateur service transmitting frequencies

~~

E1B09 (B) [97.3]

What is the Radio Amateur Civil Emergency Service (RACES)?

B. A radio service of amateur stations for civil defense communications during

~~

E1B10 (C) [97.407]

Which amateur stations may be operated in RACES?

C. Any FCC-licensed amateur station certified by the responsible civil defense

~~

E1B11 (A) [97.407]

What frequencies are normally authorized to an amateur station participating in RACES?

A. All amateur service frequencies otherwise authorized to the control operator

~~

E1B12 (B) [97.407]

What are the frequencies authorized to an amateur station participating in RACES during a period when the President's War Emergency Powers are in force?

B. Specific amateur service frequency segments authorized in FCC Part 214

~~

E1B13 (C) [97.407]

What communications are permissible in RACES?

C. Authorized civil defense emergency communications affecting the immediate safety of life and property

~~

E1C LOCAL, REMOTE AND AUTOMATIC CONTROL - 10 questions

Definitions and restrictions pertaining to local, automatic and remote control operation; amateur radio and the Internet; control operator responsibilities for remote and automatically controlled stations

E1C01 (D) [97.3]

What is a remotely controlled station?

D. A station controlled indirectly through a control link

~~

E1C02 (A) [97.3, 97.109]

What is meant by automatic control of a station?

A. The use of devices and procedures for control so that the control operator does not have to be present at a control point

~~

E1C03 (B) [97.3, 97.109]

How do the control operator responsibilities of a station under automatic control differ from one under local control?

B. Under automatic control the control operator is not required to be present at the control point

~~

E1C04 (B) [97.109]

When may an automatically controlled station retransmit third party communications?

B. Only when transmitting RTTY or data emissions

~~

E1C05 (A) [97.109]

When may an automatically controlled station originate third party communications?

A. Never

~~

E1C06 (C) [97.109]

Which of the following statements concerning remotely controlled amateur stations is true?

C. A control operator must be present at the control point

~~

E1C07 (C) [97.3]

What is meant by local control?

C. Direct manipulation of the transmitter by a control operator

~~

E1C08 (B) [97.213]

What is the maximum permissible duration of a remotely controlled station's transmissions if its control link malfunctions?

B. 3 minutes

~~

E1C09 (D) [97.205]

Which of these frequencies are available for automatically controlled ground-station repeater operation?

D. 29.500 - 29.700 MHz

~~

E1C10 (B) [97.113]

What types of amateur stations may automatically retransmit the radio signals of other amateur stations?

B. Only auxiliary, repeater or space stations

~~

E1D Amateur Satellite service: definitions and purpose; license requirements for space stations; available frequencies and bands; telecommand and telemetry operations; restrictions, and special provisions; notification requirements

E1D01 (A) [97.3]

What is the definition of the term telemetry?

A. One-way transmission of measurements at a distance from the measuring instrument

~~

E1D02 (C) [97.3]

What is the amateur-satellite service?

C. A radio communications service using amateur stations on satellites

~~

E1D03 (B) [97.3]

What is a telecommand station in the amateur satellite service?

B. An amateur station that transmits communications to initiate, modify or terminate certain functions of a space station

~~

E1D04 (A) [97.3]

What is an Earth station in the amateur satellite service?

A. An amateur station within 50 km of the Earth's surface for communications with amateur stations by means of objects in space

~~

E1D05 (C) [97.207]

What class of licensee is authorized to be the control operator of a space station?

C. A holder of any class of license

~~

E1D06 (A) [97.207]

Which of the following special provisions must a space station incorporate in order to comply with space station requirements?

A. The space station must be capable of effecting a cessation of transmissions by telecommand when so ordered by the FCC

~~

E1D07 (A) [97.207]

Which amateur service HF bands have frequencies authorized to space stations?

A. Only 40m, 20m, 17m, 15m, 12m and 10m

~~

E1D08 (D) [97.207]

Which VHF amateur service bands have frequencies available for space stations?

D. 2 meters

~~

E1D09 (B) [97.207]

Which amateur service UHF bands have frequencies available for a space station?

B. 70 cm, 23 cm, 13 cm

~~

E1D10 (B) [97.211]

Which amateur stations are eligible to be telecommand stations?

B. Any amateur station so designated by the space station licensee

~~

E1D11 (D) [97.209]

Which amateur stations are eligible to operate as Earth stations?

D. Any amateur station, subject to the privileges of the class of operator license held by the control operator

~~

E1D12 (B) [97.207]

Who must be notified before launching an amateur space station?

B. The FCC's International Bureau, Washington, DC

~~

E1E Volunteer examiner program: definitions, qualifications, preparation and administration of exams; accreditation; question pools; documentation requirements

E1E01 (D) [97.509]

What is the minimum number of qualified VEs required to administer an Element 4 amateur operator license examination?

D. 3

~~

E1E02 (C) [97.523]

Where are the questions for all written US amateur license examinations listed?

C. In the VEC-maintained question pool

~~

E1E03 (A) [97.523]

Who is responsible for maintaining the question pools from which all amateur license examination questions must be taken?

A. All of the VECs

~~

E1E04 (C) [97.521]

What is a Volunteer Examiner Coordinator?

C. An organization that has entered into an agreement with the FCC to coordinate amateur operator license examinations

~~

E1E05 (B) [97.525, 97.3]

What is a VE?

B. An amateur operator who is approved by a VEC to administer amateur operator license examinations

~~

E1E06 (A) [97.509]

What is a VE team?

A. A group of at least three VEs who administer examinations for an amateur operator license

~~

E1E07 (C) [97.509]

Which of the following persons seeking to become VEs cannot be accredited?

C. Persons who have ever had an amateur operator or amateur station license suspended or revoked

~~

E1E08 (D) [97.5091, 97.525]

Which of the following best describes the Volunteer Examiner accreditation process?

D. The procedure by which a VEC confirms that the VE applicant meets FCC requirements to serve as an examiner

~~

E1E09 (A) [97.509]

Where must the VE team be while administering an examination?

A. All of the administering VEs must be present where they can observe the examinees throughout the entire examination

~~

E1E10 (C) [97.509]

Who is responsible for the proper conduct and necessary supervision during an amateur operator license examination session?

C. Each administering VE

~~

E1E11 (B) [97.509]

What should a VE do if a candidate fails to comply with the examiner's instructions during an amateur operator license examination?

B. Immediately terminate the candidate's examination

~~

E1E12 (C) [97.509]

To which of the following examinees may a VE not administer an examination?

C. The VE's close relatives as listed in the FCC rules

~~

E1E13 (A) [97.509]

What may be the penalty for a VE who fraudulently administers or certifies an examination?

A. Revocation of the VE's amateur station license grant and the suspension of the VE's amateur operator license grant

~~

E1E14 (C) [97.509] [edited, was E1F19, edited]

What must the VE team do with the examinee's test papers once they have finished the examination?

C. The VE team must collect and grade them immediately

~~

E1E15 (B) [97.509]

What must the VE team do if an examinee scores a passing grade on all examination elements needed for an upgrade or new license?

B. Three VEs must certify that the examinee is qualified for the license grant and

~~

E1E16 (A) [97.509]

What must the VE team do with the application form if the examinee does not pass the exam?

A. Return the application document to the examinee

~~

E1E17 (A) [97.519]

What are the consequences of failing to appear for re-administration of an examination when so directed by the FCC?

A. The licensee's license will be cancelled

~~

E1E18 (A) [97.527]

For which types of out-of-pocket expenses may VEs and VECs be reimbursed?

A. Preparing, processing, administering and coordinating an examination for an amateur radio license

~~

E1E19 (A) [97.509, 97.527]

How much reimbursement may the VE team and VEC accept for preparing, processing, administering and coordinating an examination?

A. Actual out-of-pocket expenses

~~

E1E20 (C) [97.509]

What is the minimum age to be a volunteer examiner?

C. 18 years old

~~

E1F Miscellaneous rules: external RF power amplifiers; Line A; national quiet zone; business communications; compensated communications; spread spectrum; auxiliary stations; reciprocal operating privileges; IARP and CEPT licenses; third party communications with foreign countries; special temporary authority

E1F01 (B) [97.305]

On what frequencies are spread spectrum transmissions permitted?

B. Only on amateur frequencies above 222 MHz

~~

E1F02 (A) [97.5]

Which of the following operating arrangements allows an FCC-licensed US citizen to operate in many European countries, and alien amateurs from many European countries to operate in the US?

A. CEPT agreement

~~

E1F03 (B) [97.5]

Which of the following operating arrangements allow an FCC-licensed US citizen and many Central and South American amateur operators to operate in each other's countries?

B. IARP agreement

~~

E1F04 (B) [97.315]

What does it mean if an external RF amplifier is listed on the FCC database as certificated for use in the amateur service?

B. That particular RF amplifier may be marketed for use in the amateur service

~~

E1F05 (A) [97.315]

Under what circumstances may a dealer sell an external RF power amplifier capable of operation below 144 MHz if it has not been granted FCC certification?

A. It was purchased in used condition from an amateur operator and is sold to another amateur operator for use at that operator's station

~~

E1F06 (A) [97.3]

Which of the following geographic descriptions approximately describes "Line A"?

A. A line roughly parallel to and south of the US-Canadian border

~~

E1F07 (D) [97.303]

Amateur stations may not transmit in which of the following frequency segments if they are located north of Line A?

D. 420 - 430 MHz

~~

E1F08 (C) [97.3]

What is the National Radio Quiet Zone?

C. An area surrounding the National Radio Astronomy Observatory

~~

E1F09 (D) [97.113]

When may the control operator of a repeater accept payment for providing communication services to another party?

D. Under no circumstances

~~

E1F10 (D) [97.113]

When may an amateur station send a message to a business?

D. When neither the amateur nor his or her employer has a pecuniary interest in the communications

~~

E1F11 (A) [97.113]

Which of the following types of amateur-operator-to-amateur-operator communications are prohibited?

A. Communications transmitted for hire or material compensation, except as otherwise provided in the rules

~~

E1F12 (D) [97.311]

FCC-licensed amateur stations may use spread spectrum (SS) emissions to communicate under which of the following conditions?

A. When the other station is in an area regulated by the FCC

B. When the other station is in a country permitting SS communications

C. When the transmission is not used to obscure the meaning of any communication

D. All of these choices are correct

~~

E1F13 (C) [97.311]

What is the maximum transmitter power for an amateur station transmitting spread spectrum communications?

C. 100 W

~~

E1F14 (D) [97.317]

Which of the following best describes one of the standards that must be met by an external RF power amplifier if it is to qualify for a grant of FCC certification?

D. It must satisfy the FCC's spurious emission standards when operated at its full output power

~~

E1F15 (B) [97.201]

Who may be the control operator of an auxiliary station?

B. Only Technician, General, Advanced or Amateur Extra Class operators

~~

E1F16 (C) [97.117]

What types of communications may be transmitted to amateur stations in foreign countries?

C. Communications incidental to the purpose of the amateur service and remarks of a personal nature

~~

E1F17 (A) [1.931]

Under what circumstances might the FCC issue a "Special Temporary Authority" (STA) to an amateur station?

A. To provide for experimental amateur communications

~~

SUBELEMENT E2 - OPERATING PRACTICES AND PROCEDURES [5 Exam Questions - 5 Groups]

E2A Amateur radio in space: amateur satellites; orbital mechanics; frequencies and modes; satellite hardware; satellite operations

E2A01 (C)

What is the direction of an ascending pass for an amateur satellite?

C. From south to north

~~

E2A02 (A)

What is the direction of a descending pass for an amateur satellite?

A. From north to south

~~

E2A03 (C)

What is the orbital period of a satellite?

C. The time it takes for a satellite to complete one revolution around the Earth

~~

E2A04 (B)

What is meant by the term "mode" as applied to an amateur radio satellite?

B. The satellite's uplink and downlink frequency bands

~~

E2A05 (D)

What do the letters in a satellite's mode designator specify?

D. The uplink and downlink frequencies

~~

E2A06 (A)

On what band would a satellite receive signals if it were operating in mode U/V?

A. 432 MHz

~~

E2A07 (D)

Which of the following types of signals can be relayed through a linear transponder?

A. FM and CW

B. SSB and SSTV

C. PSK and Packet

D. All these answers are correct

~~

E2A08 (B)

What is the primary reason for satellite users to limit their transmit ERP?

B. Because the satellite transmitter output power is limited

~~

E2A09 (A)

What do the terms L band and S band specify with regard to satellite communications?

A. The 23 centimeter and 13 centimeter bands

~~

E2A10 (A)

Why may the received signal from an amateur satellite exhibit a rapidly repeating fading effect?

A. Because the satellite is rotating

~~

E2A11 (B)

What type of antenna can be used to minimize the effects of spin modulation and Faraday rotation?

B. A circularly polarized antenna

~~

E2A12 (D)

What is one way to predict the location of a satellite at a given time?

D. By calculations using the Keplerian elements for the specified satellite

~~

E2A13 (B)

What type of satellite appears to stay in one position in the sky?

B. Geosynchronous

~~

E2A14 (B)

What happens to a satellite's transmitted signal due to the Doppler Effect?

B. The signal frequency shifts lower as the satellite passes overhead

~~

E2B Television practices: fast scan television standards and techniques; slow scan television standards and techniques

E2B01 (A) [edited]

How many times per second is a new frame transmitted in a fast-scan (NTSC) television system?

A. 30

~~

E2B02 (C)

How many horizontal lines make up a fast-scan (NTSC) television frame?

C. 525

~~

E2B03 (D)

How is an interlace scanning pattern generated in a fast-scan (NTSC) television system?

D. By scanning odd numbered lines in one field and even numbered ones in the next

~~

E2B04 (B)

What is blanking in a video signal?

B. Turning off the scanning beam while it is traveling from right to left or from bottom to top

~~

E2B05 (C)

Which of the following is an advantage of using vestigial sideband for standard fast scan TV transmissions?

C. Vestigial sideband reduces bandwidth while allowing for simple video detector circuitry

~~

E2B06 (A)

What is vestigial sideband modulation?

A. Amplitude modulation in which one complete sideband and a portion of the other sideband is transmitted

~~

E2B07 (B)

What is the name of the video signal component that carries color information?

B. Chroma

~~

E2B08 (D)

Which of the following is a common method of transmitting accompanying audio with amateur fast-scan television?

- A. Frequency-modulated sub-carrier
- B. A separate VHF or UHF audio link
- C. Frequency modulation of the video carrier
- D. All of these choices are correct

~~

E2B09 (D)

What hardware, other than a transceiver with SSB capability and a suitable computer, is needed to decode SSTV based on Digital Radio Mondiale (DRM)?

D. No other hardware is needed

~~

E2B10 (A)

Which of the following is an acceptable bandwidth for Digital Radio Mondiale (DRM) based voice or SSTV digital transmissions made on the HF amateur bands?

A. 3 KHz

~~

E2B11 (B)

What is the function of the Vertical Interval Signaling (VIS) code transmitted as part of an SSTV transmission?

B. To identify the SSTV mode being used

~~

E2B12 (D)

How are analog slow-scan television images typically transmitted on the HF bands?

D. Varying tone frequencies representing the video are transmitted using single sideband

~~

E2B13 (C)

How many lines are commonly used in each frame on an amateur slow-scan color television picture?

C. 128 or 256

~~

E2B14 (A)

What aspect of an amateur slow-scan television signal encodes the brightness of the picture?

A. Tone frequency

~~

E2B15 (A)

What signals SSTV receiving equipment to begin a new picture line?

A. Specific tone frequencies

~~

E2B16 (D)

Which of the following is the video standard used by North American Fast Scan ATV stations?

D. NTSC

~~

E2B17 (A)

Which of the following is NOT a characteristic of FMTV (Frequency-Modulated Amateur Television) as compared to vestigial sideband AM television?

A. Immunity from fading due to limiting

~~

E2B18 (B)

What is the approximate bandwidth of a slow-scan TV signal?

B. 3 kHz

~~

E2B19 (D)

On which of the following frequencies is one likely to find FMTV transmissions?

D. 1255 MHz

~~

E2B20 (C)

What special operating frequency restrictions are imposed on slow scan TV transmissions?

C. They are restricted to phone band segments and their bandwidth can be no greater than that of a voice signal of the same modulation type

~~

E2B21 (B) [NEW, adapted from E2B16]

If 100 IRE units correspond to the most-white level in the NTSC standard video format, what is the level of the most-black signal?

B. 7.5 IRE units

~~

E2C Operating methods, part 1: contest and DX operating; spread-spectrum transmissions; automatic HF forwarding; selecting an operating frequency

E2C01 (A)

Which of the following is true about contest operating?

A. Operators are permitted to make contacts even if they do not submit a log

~~

E2C02 (A)

Which of the following best describes "self spotting" in regards to contest operating?

A. The generally prohibited practice of posting one's own call sign and frequency on a call sign spotting network

~~

E2C03 (A)

From which of the following bands is amateur radio contesting generally excluded?

A. 30 meters

~~

E2C04 (D)

On which of the following frequencies is an amateur radio contest contact generally discouraged?

D. 146.52 MHz

~~

E2C05 (B) [97.301]

Which of the following frequencies would generally be acceptable for U.S. stations to work other U.S. stations in a phone contest?

B. 14.310 MHz

~~

E2C06 (C)

During a VHF/UHF contest, in which band segment would you expect to find the highest level of activity?

C. In the weak signal segment of the band, with most of the activity near the calling frequency

~~

E2C07 (A)

What is the Cabrillo format?

A. A standard for organizing information in contest log files

~~

E2C08 (A)

Why are received spread-spectrum signals resistant to interference?

A. Signals not using the spectrum-spreading algorithm are suppressed in the receiver

~~

E2C09 (D)

How does the spread-spectrum technique of frequency hopping (FH) work?

D. The frequency of the transmitted signal is changed very rapidly according to a particular sequence also used by the receiving station

~~

E2C10 (D)

Why might a phone DX station state that he is listening on another frequency?

A. Because the DX station may be transmitting on a frequency that is prohibited to some responding stations

B. To separate the calling stations from the DX station

C. To reduce interference, thereby improving operating efficiency

D. All of these choices are correct

~~

E2C11 (A)

How should you generally sign your call when attempting to contact a DX station working a "pileup" or in a contest?

A. Send your full call sign once or twice

~~

E2C12 (B)

In North America during low sunspot activity, when signals from Europe become weak and fluttery across an entire HF band two to three hours after sunset, what might help to contact other European DX stations?

B. Switch to a lower frequency HF band

~~

E2D Operating methods, part 2: VHF and UHF digital modes; packet clusters; Automatic Position Reporting System (APRS)

E2D01 (B)

What does "command mode" mean in packet operations?

B. The TNC is ready to receive instructions via the keyboard

~~

E2D02 (A)

What is the definition of "baud"?

A. The number of data symbols transmitted per second

~~

E2D03 (A)

Which of the follow is true when comparing HF and 2-meter packet operations?

A. HF packet typically uses FSK with a data rate of 300 baud; 2-meter packet uses AFSK with a data rate of 1200 baud

~~

E2D04 (C)

What is the purpose of digital store-and-forward functions on an Amateur satellite?

C. To store digital messages in the satellite for later download by other stations

~~

E2D05 (B)

Which of the following techniques is normally used by low-earth orbiting digital satellites to relay messages around the world?

B. Store-and-forward

~~

E2D06 (B)

Which of the following is a commonly used 2-meter APRS frequency?

B. 144.39 MHz

~~

E2D07 (A)

Which of the following digital protocols is used by APRS?

A. AX.25

~~

E2D08 (D)

Which of the following types of packet frames is used to transmit APRS beacon data?

D. Unnumbered Information frames

~~

E2D09 (D)

Under clear communications conditions, which of these digital communications modes has the fastest data throughput?

D. 300-baud packet

~~

E2D10 (C)

How can an APRS station be used to help support a public service communications activity?

C. An APRS station with a GPS unit can automatically transmit information to show a mobile station's position during the event

~~

E2D11 (D)

Which of the following data sources are needed to accurately transmit your geographical location over the APRS network?

- A. The NMEA-0183 formatted data from a Global Positioning System (GPS) satellite receiver
- B. The latitude and longitude of your location, preferably in degrees, minutes and seconds, entered into the APRS computer software
- C. The NMEA-0183 formatted data from a LORAN navigation system
- D. Any of these choices is correct

~~

E2E Operating methods, part 3: operating HF digital modes; error correction

E2E01 (B)

What is a common method of transmitting data emissions below 30 MHz?

- B. FSK/AFSK

~~

E2E02 (A)

What do the letters FEC mean as they relate to digital operation?

- A. Forward Error Correction

~~

E2E03 (C)

How is Forward Error Correction implemented?

- C. By transmitting extra data that may be used to detect and correct transmission errors

~~

E2E04 (A)

What is indicated when one of the ellipses in an FSK crossed-ellipse display suddenly disappears?

- A. Selective fading has occurred

~~

E2E05 (D)

How does ARQ accomplish error correction?

- D. If errors are detected, a retransmission is requested

~~

E2E06 (C)

What is the most common data rate used for HF packet communications?

- C. 300 baud

~~

E2E07 (B)

What is the typical bandwidth of a properly modulated MFSK16 signal?

- B. 316 Hz

~~

E2E08 (B)

Which of the following HF digital modes can be used to transfer binary files?

- B. PACTOR

~~

E2E09 (D)

Which of the following HF digital modes uses variable-length coding for bandwidth efficiency?

D. PSK31

~~

***** E2E10 This question has been removed by the QPC

E2E11 (D)

What is the Baudot code?

D. The International Telegraph Alphabet Number 2 (ITA2) which uses five data bits

~~

E2E12 (C)

Which of these digital communications modes has the narrowest bandwidth?

C. PSK31

~~

SUBELEMENT E3 -- RADIO WAVE PROPAGATION [3 Exam Questions -- 3 Groups]

E3A Propagation and technique, part 1: Earth-Moon-Earth communications (EME); meteor scatter

E3A01 (D)

What is the approximate maximum separation along the surface of the Earth between two stations communicating by moonbounce?

D. 12,000 miles, as long as both can "see" the moon

~~

E3A02 (B)

What characterizes libration fading of an earth-moon-earth signal?

B. A fluttery irregular fading

~~

E3A03 (A)

When scheduling EME contacts, which of these conditions will generally result in the least path loss?

A. When the moon is at perigee

~~

E3A04 (D) edited A

What type of receiving system is desirable for EME communications?

D. Equipment with very low noise figures

~~

E3A05 (A)

What transmit and receive time sequencing is normally used on 144 MHz when attempting an EME contact?

A. Two-minute sequences, where one station transmits for a full two minutes and then receives for the following two minutes

~~

E3A06 (C)

What transmit and receive time sequencing is normally used on 432 MHz when attempting an EME contact?

C. Two-and-one-half minute sequences, where one station transmits for a full 2.5 minutes and then receives for the following 2.5 minutes

~~

E3A07 (B)

What frequency range would you normally tune to find EME stations in the 2 meter band?

B. 144.000 - 144.100 MHz

~~

E3A08 (D)

What frequency range would you normally tune to find EME stations in the 70 cm band?

D. 432.000 - 432.100 MHz

~~

E3A09 (A)

When a meteor strikes the Earth's atmosphere, a cylindrical region of free electrons is formed at what layer of the ionosphere?

A. The E layer

~~

E3A10 (C)

Which range of frequencies is well suited for meteor-scatter communications?

C. 28 - 148 MHz

~~

E3A11 (C)

What transmit and receive time sequencing is normally used on 144 MHz when attempting a meteor-scatter contact?

C. 15-second sequences, where one station transmits for 15 seconds and then receives for the following 15 seconds

~~

E3B Propagation and technique, part 2: transequatorial; long path; gray line; multi-path propagation

E3B01 (A)

What is transequatorial propagation?

A. Propagation between two points at approximately the same distance north and south of the magnetic equator

~~

E3B02 (C)

What is the approximate maximum range for signals using transequatorial propagation?

C. 5000 miles

~~

E3B03 (C)

What is the best time of day for transequatorial propagation?

C. Afternoon or early evening

~~

E3B04 (A)

What type of propagation is probably occurring if an HF beam antenna must be pointed in a direction 180 degrees away from a station to receive the strongest signals?

A. Long-path

~~

E3B05 (C)

Which amateur bands typically support long-path propagation?

C. 160 to 10 meters

~~

E3B06 (B)

Which of the following amateur bands most frequently provides long-path propagation?

B. 20 meters

~~

E3B07 (D)

Which of the following could account for hearing an echo on the received signal of a distant station?

D. Receipt of a signal by more than one path

~~

E3B08 (D)

What type of propagation is probably occurring if radio signals travel along the terminator between daylight and darkness?

D. Gray-line

~~

E3B09 (A) [edited A]

At what time of day is gray-line propagation most prevalent?

A. At sunrise and sunset

~~

E3B10 (B)

What is the cause of gray-line propagation?

B. At twilight, solar absorption drops greatly, while atmospheric ionization is not weakened enough to reduce the MUF

noon, the sun heats the ionosphere, increasing radio wave refraction and the MUF

~~

E3B11 (C)

What communications are possible during gray-line propagation?

C. Contacts up to 8,000 to 10,000 miles on three or four HF bands

~~

E3C Propagation and technique, part 3: Auroral propagation; selective fading; radio-path horizon; take-off angle over flat or sloping terrain; earth effects on propagation; less common propagation modes

E3C01 (D)

What effect does auroral activity have on radio communications?

D. CW signals have a fluttery tone

~~

E3C02 (C)

What is the cause of auroral activity?

C. The emission of charged particles from the sun

~~

E3C03 (D)

Where in the ionosphere does auroral activity occur?

D. At E-region height

~~

E3C04 (A)

Which emission mode is best for auroral propagation?

A. CW

~~

E3C05 (B)

What causes selective fading?

B. Phase differences in the received signal caused by different paths

~~

E3C06 (A)

How much farther does the VHF/UHF radio-path horizon distance exceed the geometric horizon?

A. By approximately 15% of the distance

~~

E3C07 (B)

How does the radiation pattern of a 3-element, horizontally polarized beam antenna vary with height above ground?

B. The main lobe takeoff angle decreases with increasing height

~~

E3C08 (B)

What is the name of the high-angle wave in HF propagation that travels for some distance within the F2 region?

B. Pedersen ray

~~

E3C09 (C)

What effect is usually responsible for propagating a VHF signal over 500 miles?

C. Tropospheric ducting

~~

E3C10 (B)

How does the performance of a horizontally polarized antenna mounted on the side of a hill compare with the same antenna mounted on flat ground?

B. The main lobe takeoff angle decreases in the downhill direction

~~

E3C11 (B)

From the contiguous 48 states, in which approximate direction should an antenna be pointed to take maximum advantage of auroral propagation?

B. North

~~

E3C12 (B)

As the frequency of a signal is increased, how does its ground wave propagation change?

B. It decreases

~~

E3C13 (A)

What type of polarization does most ground-wave propagation have?

A. Vertical

~~

E3C14 (D)

Why does the radio-path horizon distance exceed the geometric horizon?

D. Radio waves may be bent

~~

SUBELEMENT E4 -- AMATEUR RADIO TECHNOLOGY AND MEASUREMENTS [5 Exam Questions -- 5 Groups]

E4A Test equipment: analog and digital instruments; spectrum and network analyzers, antenna analyzers; oscilloscopes; testing transistors; RF measurements

E4A01 (C)

How does a spectrum analyzer differ from a conventional oscilloscope?

C. A spectrum analyzer displays signals in the frequency domain; an oscilloscope displays signals in the time domain

~~

E4A02 (D)

Which of the following parameters would a typical spectrum analyzer display on the horizontal axis?

D. Frequency

~~

E4A03 (A)

Which of the following parameters would a typical spectrum analyzer display on the vertical axis?

A. Amplitude

~~

E4A04 (A)

Which of the following test instruments is used to display spurious signals from a radio transmitter?

A. A spectrum analyzer

~~

E4A05 (B)

Which of the following test instruments is used to display intermodulation distortion products in an SSB transmission?

B. A spectrum analyzer

~~

E4A06 (D)

Which of the following could be determined with a spectrum analyzer?

A. The degree of isolation between the input and output ports of a 2 meter duplexer

B. Whether a crystal is operating on its fundamental or overtone frequency

C. The spectral output of a transmitter

D. All of these choices are correct

~~

E4A07 (B)

Which of the following is an advantage of using an antenna analyzer vs. a SWR bridge to measure antenna SWR?

B. Antenna analyzers typically do not need an external RF source

~~

E4A08 (D)

Which of the following instruments would be best for measuring the SWR of a beam antenna?

D. An antenna analyzer

~~

E4A09 (C)

Which of the following is most important when adjusting PSK31 transmitting levels?

C. ALC level

~~

E4A10 (D)

Which of the following is a useful test for a functioning NPN transistor in an active circuit where the transistor should be biased "on" ?

D. Measure base-to-emitter voltage with a voltmeter; it should be approximately 0.6 to 0.7 volts

~~

E4A11 (A)

Which of the following test instruments can be used to indicate pulse conditions in a digital logic circuit?

A. A logic probe

~~

E4A12 (B)

Which of the following procedures is an important precaution to follow when connecting a spectrum analyzer to a transmitter output?

B. Attenuate the transmitter output going to the spectrum analyzer

~~

E4B Measurement technique and limitations: instrument accuracy and performance limitations; probes; techniques to minimize errors; measurement of "Q"; instrument calibration

E4B01 (B)

Which of the following is a characteristic of a good harmonic frequency marker?

B. Frequency stability

~~

E4B02 (B)

Which of the following factors most affects the accuracy of a frequency counter?

B. Time base accuracy

~~

E4B03 (C)

What is an advantage of using a bridge circuit to measure impedance?

C. The measurement is based on obtaining a null in voltage, which can be done very precisely

~~

E4B04 (C)

If a frequency counter with a specified accuracy of ± 1.0 ppm reads 146,520,000 Hz, what is the most the actual frequency being measured could differ from the reading?

C. 146.52 Hz

~~

E4B05 (A)

If a frequency counter with a specified accuracy of ± 0.1 ppm reads 146,520,000 Hz, what is the most the actual frequency being measured could differ from the reading?

A. 14.652 Hz

~~

E4B06 (D)

If a frequency counter with a specified accuracy of ± 10 ppm reads 146,520,000 Hz, what is the most the actual frequency being measured could differ from the reading?

D. 1465.20 Hz

~~

E4B07 (D)

How much power is being absorbed by the load when a directional power meter connected between a transmitter and a terminating load reads 100 watts forward power and 25 watts reflected power?

D. 75 watts

~~

E4B08 (A)

Which of the following is good practice when using an oscilloscope probe?

A. Keep the ground connection of the probe as short as possible

~~

E4B09 (C)

Which of the following is a characteristic of a good DC voltmeter?

C. High impedance input

~~

E4B10 (D)

What is indicated if the current reading on an RF ammeter placed in series with the antenna feedline of a transmitter increases as the transmitter is tuned to resonance?

D. There is more power going into the antenna

~~

E4B11 (B)

Which of the following describes a method to measure intermodulation distortion in an SSB transmitter?

B. Modulate the transmitter with two non-harmonically related audio frequencies and observe the RF output with a spectrum analyzer

~~

E4B12 (D)

How should a portable SWR analyzer be connected when measuring antenna resonance and feedpoint impedance?

D. Connect the antenna feed line directly to the analyzer's connector

~~

E4B13 (A)

What is the significance of voltmeter sensitivity expressed in ohms per volt?

A. The full scale reading of the voltmeter multiplied by its ohms per volt rating will provide the input impedance of the voltmeter

~~

E4B14 (A)

How is the compensation of an oscilloscope probe typically adjusted?

A. A square wave is observed and the probe is adjusted until the horizontal portions of the displayed wave is as nearly flat as possible

~~

E4B15 (B)

What happens if a dip-meter is too tightly coupled to a tuned circuit being checked?

B. A less accurate reading results

~~

E4B16 (B)

Which of these factors limits the accuracy of a D'Arsonval-type meter?

B. Coil impedance

~~

E4B17 (C)

Which of the following can be used as a relative measurement of the Q for a series-tuned circuit?

C. The bandwidth of the circuit's frequency response

~~

E4C Receiver performance characteristics, part 1: phase noise, capture effect, noise floor, image rejection, MDS, signal-to-noise-ratio; selectivity

E4C01 (D)

What is the effect of excessive phase noise in the local oscillator section of a receiver?

D. It can cause strong signals on nearby frequencies to interfere with reception of weak signals

~~

E4C02 (C)

Which of the following is the result of the capture effect in an FM receiver?

C. The strongest signal received is the only demodulated signal

~~

E4C03 (C)

What is the term for the blocking of one FM phone signal by another, stronger FM phone signal?

C. Capture effect

~~

E4C04 (D)

What is meant by the noise floor of a receiver?

D. The equivalent input noise power when the antenna is replaced with a matched dummy load

~~

E4C05 (B)

What does a value of -174 dBm/Hz represent with regard to the noise floor of a receiver?

B. The theoretical noise at the input of a perfect receiver at room temperature

~~

E4C06 (D)

The thermal noise value of a receiver is -174 dBm/Hz. What is the theoretically best minimum detectable signal for a 400 Hz bandwidth receiver?

D. -148 dBm

~~

E4C07 (B)

What does the MDS of a receiver represent?

B. The minimum discernible signal

~~

E4C08 (B)

How might lowering the noise figure affect receiver performance?

B. It would increase signal to noise ratio

~~

E4C09 (D)

Which of the following is most likely to be the limiting condition for sensitivity in a modern communications receiver operating at 14 MHz?

D. Atmospheric noise

~~

E4C10 (B)

Which of the following is a desirable amount of selectivity for an amateur RTTY HF receiver?

B. 300 Hz

~~

E4C11 (B)

Which of the following is a desirable amount of selectivity for an amateur single-sideband phone receiver?

B. 2.4 kHz

~~

E4C12 (D)

What is an undesirable effect of using too wide a filter bandwidth in the IF section of a receiver?

D. Undesired signals may be heard

~~

E4C13 (C)

How does a narrow band roofing filter affect receiver performance?

C. It improves dynamic range by keeping strong signals near the receive frequency out of the IF stages

~~

E4C14 (D)

Which of these choices is a desirable amount of selectivity for an amateur VHF FM receiver?

D. 15 kHz

~~

E4C15 (D)

What is the primary source of noise that can be heard from an HF-band receiver with an antenna connected?

D. Atmospheric noise

~~

E4D Receiver performance characteristics, part 2: blocking dynamic range, intermodulation and cross-modulation interference; 3rd order intercept; desensitization; preselection

E4D01 (A)

What is meant by the blocking dynamic range of a receiver?

A. The difference in dB between the level of an incoming signal which will cause 1 dB of gain compression, and the level of the noise floor

~~

E4D02 (A)

Which of the following describes two types of problems caused by poor dynamic range in a communications receiver?

A. Cross modulation of the desired signal and desensitization from strong adjacent signals

~~

E4D03 (B)

How can intermodulation interference between two repeaters occur?

B. When the repeaters are in close proximity and the signals mix in one or both transmitter final amplifiers

~~

E4D04 (B)

What is an effective way to reduce or eliminate intermodulation interference between two repeater transmitters operating in close proximity to one another?

B. By installing a properly terminated circulator at the output of the transmitter

~~

E4D05 (A)

If a receiver tuned to 146.70 MHz receives an intermodulation-product signal whenever a nearby transmitter transmits on 146.52 MHz, what are the two most likely frequencies for the other interfering signal?

A. 146.34 MHz and 146.61 MHz

~~

E4D06 (D)

If the signals of two transmitters mix together in one or both of their final amplifiers, and unwanted signals at the sum and difference frequencies of the original signals are generated, what is this called?

D. Intermodulation interference

~~

E4D07 (D)

Which of the following describes the most significant effect of an off-frequency signal when it is causing cross-modulation interference to a desired signal?

D. The off-frequency unwanted signal is heard in addition to the desired signal

~~

E4D08 (C)

What causes intermodulation in an electronic circuit?

C. Nonlinear circuits or devices

~~

E4D09 (C)

What is the purpose of the preselector in a communications receiver?

C. To improve rejection of unwanted signals

~~

E4D10 (C)

What does a third-order intercept level of 40 dBm mean with respect to receiver performance?

C. A pair of 40 dBm signals will theoretically generate the same output on the third order intermodulation frequency as on the input frequency

~~

E4D11 (A)

Why are third-order intermodulation products within a receiver of particular interest compared to other products?

A. The third-order product of two signals which are in the band is itself likely to be within the band

~~

E4D12 (A)

What is the term for the reduction in receiver sensitivity caused by a strong signal near the received frequency?

A. Desensitization

~~

E4D13 (B)

Which of the following can cause receiver desensitization?

B. Strong adjacent-channel signals

~~

E4D14 (A)

Which of the following is a way to reduce the likelihood of receiver desensitization?

A. Decrease the RF bandwidth of the receiver

~~

E4E Noise suppression: system noise; electrical appliance noise; line noise; locating noise sources; DSP noise reduction; noise blankers

E4E01 (A)

Which of the following types of receiver noise can often be reduced by use of a receiver noise blanker?

A. Ignition Noise

~~

E4E02 (D)

Which of the following types of receiver noise can often be reduced with a DSP noise filter?

A. Broadband "white" noise

B. Ignition noise

C. Power line noise

D. All of these choices are correct

~~

E4E03 (B)

Which of the following signals might a receiver noise blanker be able to remove from desired signals?

B. Signals which appear correlated across a wide bandwidth-

~~

E4E04 (D)

How can conducted and radiated noise caused by an automobile alternator be suppressed?

D. By connecting the radio's power leads directly to the battery and by installing coaxial capacitors in line with the alternator leads

~~

E4E05 (B)

How can noise from an electric motor be suppressed?

B. By installing a brute-force AC-line filter in series with the motor leads

~~

E4E06 (B)

What is a major cause of atmospheric static?

B. Thunderstorms

~~

E4E07 (C)

How can you determine if line-noise interference is being generated within your home?

C. By turning off the AC power line main circuit breaker and listening on a battery-operated radio

~~

E4E08 (A)

What type of signal is picked up by electrical wiring near a radio transmitter?

A. A common-mode signal at the frequency of the radio transmitter

~~

E4E09 (C)

What undesirable effect can occur when using an IF type noise blanker?

C. Nearby signals may appear to be excessively wide even if they meet emission standards

~~

E4E10 (D)

What is a common characteristic of interference caused by a "touch controlled" electrical device?

A. The interfering signal sounds like AC hum on an AM receiver or a carrier modulated by 60 Hz FM on a SSB or CW receiver

B. The interfering signal may drift slowly across the HF spectrum

C. The interfering signal can be several kHz in width and usually repeats at regular intervals across a HF band

D. All of these answers are correct

~~

E4E11 (B)

What is the most likely cause if you are hearing combinations of local AM broadcast signals inside one or more of the MF or HF ham bands?

B. Nearby corroded metal joints are mixing and re-radiating the BC signals

~~

E4E12 (A)

What is one disadvantage of using some automatic DSP notch-filters when attempting to copy CW signals?

A. The DSP filter can remove the desired signal at the same time as it removes interfering signals

~~

E4E13 (D)

What might be the cause of a loud "roaring" or "buzzing" AC line type of interference that comes and goes at intervals?

- A. Arcing contacts in a thermostatically controlled device
- B. A defective doorbell or doorbell transformer inside a nearby residence
- C. A malfunctioning illuminated advertising display
- D. All of these answers are correct

~~

E4E14 (C)

What is one type of electrical interference that might be caused by the operation of a nearby personal computer?

- C. The appearance of unstable modulated or unmodulated signals at specific frequencies

~~

SUBELEMENT E5 -- ELECTRICAL PRINCIPLES [4 Exam Questions -- 4 Groups]

E5A Resonance and Q: characteristics of resonant circuits: series and parallel resonance; Q; half-power bandwidth; phase relationships in reactive circuits

E5A01 (A)

What can cause the voltage across reactances in series to be larger than the voltage applied to them?

- A. Resonance

~~

E5A02 (C)

What is resonance in an electrical circuit?

- C. The frequency at which the capacitive reactance equals the inductive reactance

~~

E5A03 (D)

What is the magnitude of the impedance of a series R-L-C circuit at resonance?

- D. Approximately equal to circuit resistance

~~

E5A04 (A)

What is the magnitude of the impedance of a circuit with a resistor, an inductor and a capacitor all in parallel, at resonance?

- A. Approximately equal to circuit resistance

~~

E5A05 (B)

What is the magnitude of the current at the input of a series R-L-C circuit as the frequency goes through resonance?

- B. Maximum

~~

E5A06 (B) (Was E5A08; edited]

What is the magnitude of the circulating current within the components of a parallel L-C circuit at resonance?

- B. It is at a maximum

E5A07 (A)

What is the magnitude of the current at the input of a parallel R-L-C circuit at resonance?

A. Minimum

~~

E5A08 (C)

What is the phase relationship between the current through and the voltage across a series resonant circuit?

C. The voltage and current are in phase

~~

E5A09 (C)

What is the phase relationship between the current through and the voltage across a parallel resonant circuit?

C. The voltage and current are in phase

~~

E5A10 (A)

What is the half-power bandwidth of a parallel resonant circuit that has a resonant frequency of 1.8 MHz and a Q of 95?

A. 18.9 kHz

~~

E5A11 (C)

What is the half-power bandwidth of a parallel resonant circuit that has a resonant frequency of 7.1 MHz and a Q of 150?

C. 47.3 kHz

~~

E5A12 (C)

What is the half-power bandwidth of a parallel resonant circuit that has a resonant frequency of 3.7 MHz and a Q of 118?

C. 31.4 kHz

~~

E5A13 (B)

What is the half-power bandwidth of a parallel resonant circuit that has a resonant frequency of 14.25 MHz and a Q of 187?

B. 76.2 kHz

~~

E5A14 (C)

What is the resonant frequency of a series RLC circuit if R is 22 ohms, L is 50 microhenrys and C is 40 picofarads?

C. 3.56 MHz

~~

E5A15 (B)

What is the resonant frequency of a series RLC circuit if R is 56 ohms, L is 40 microhenrys and C is 200 picofarads?

B. 1.78 MHz

~~

E5A16 (D)

What is the resonant frequency of a parallel RLC circuit if R is 33 ohms, L is 50 microhenrys and C is 10 picofarads?

D. 7.12 MHz

~~

E5A17 (A)

What is the resonant frequency of a parallel RLC circuit if R is 47 ohms, L is 25 microhenrys and C is 10 picofarads?

A. 10.1 MHz

~~

E5B Time constants and phase relationships: R/L/C time constants: definition; time constants in RL and RC circuits; phase angle between voltage and current; phase angles of series and parallel circuits

E5B01(B)

What is the term for the time required for the capacitor in an RC circuit to be charged to 63.2% of the supply voltage?

B. One time constant

~~

E5B02 (D)

What is the term for the time it takes for a charged capacitor in an RC circuit to discharge to 36.8% of its initial value of stored charge?

D. One time constant

~~

E5B03 (D)

The capacitor in an RC circuit is discharged to what percentage of the starting voltage after two time constants?

D. 13.5%

~~

E5B04 (D)

What is the time constant of a circuit having two 220-microfarad capacitors and two 1-megohm resistors all in parallel?

D. 220 seconds

~~

E5B05 (A)

How long does it take for an initial charge of 20 V DC to decrease to 7.36 V DC in a 0.01-microfarad capacitor when a 2-megohm resistor is connected across it?

A. 0.02 seconds

~~

E5B06 (C)

How long does it take for an initial charge of 800 V DC to decrease to 294 V DC in a 450-microfarad capacitor when a 1-megohm resistor is connected across it?

C. 450 seconds

~~

E5B07 (C)

What is the phase angle between the voltage across and the current through a series R-L-C circuit if XC is 500 ohms, R is 1 kilohm, and XL is 250 ohms?

C. 14.0 degrees with the voltage lagging the current

~~

E5B08 (A)

What is the phase angle between the voltage across and the current through a series R-L-C circuit if XC is 100 ohms, R is 100 ohms, and XL is 75 ohms?

A. 14 degrees with the voltage lagging the current

~~

E5B09 (D) was E5D06

What is the relationship between the current through and the voltage across a capacitor?

D. Current leads voltage by 90 degrees

~~

E5B10 (A) was E5D07

What is the relationship between the current through an inductor and the voltage across an inductor?

A. Voltage leads current by 90 degrees

~~

E5B11 (B) was E5D08

What is the phase angle between the voltage across and the current through a series RLC circuit if XC is 25 ohms, R is 100 ohms, and XL is 50 ohms?

B. 14 degrees with the voltage leading the current

~~

E5B12 (C) was E5D10

What is the phase angle between the voltage across and the current through a series RLC circuit if XC is 75 ohms, R is 100 ohms, and XL is 50 ohms?

C. 14 degrees with the voltage lagging the current

~~

E5B13 (D) was E5D11

What is the phase angle between the voltage across and the current through a series RLC circuit if XC is 250 ohms, R is 1 kilohm, and XL is 500 ohms?

D. 14.04 degrees with the voltage leading the current

~~

E5C Impedance plots and coordinate systems: plotting impedances in polar coordinates; rectangular coordinates

E5C01 (B)

In polar coordinates, what is the impedance of a network consisting of a 100-ohm-reactance inductor in series with a 100-ohm resistor?

B. 141 ohms at an angle of 45 degrees

~~

E5C02 (D)

In polar coordinates, what is the impedance of a network consisting of a 100-ohm-reactance inductor, a 100-ohm-reactance capacitor, and a 100-ohm resistor, all connected in series?

D. 100 ohms at an angle of 0 degrees

~~

E5C03 (A)

In polar coordinates, what is the impedance of a network consisting of a 300-ohm-reactance capacitor, a 600-ohm-reactance inductor, and a 400-ohm resistor, all connected in series?

A. 500 ohms at an angle of 37 degrees

~~

E5C04 (D)

In polar coordinates, what is the impedance of a network consisting of a 400-ohm-reactance capacitor in series with a 300-ohm resistor?

D. 500 ohms at an angle of -53.1 degrees

~~

E5C05 (A)

In polar coordinates, what is the impedance of a network consisting of a 400-ohm-reactance inductor in parallel with a 300-ohm resistor?

A. 240 ohms at an angle of 36.9 degrees

~~

E5C06 (D)

In polar coordinates, what is the impedance of a network consisting of a 100-ohm-reactance capacitor in series with a 100-ohm resistor?

D. 141 ohms at an angle of -45 degrees

~~

E5C07 (C)

In polar coordinates, what is the impedance of a network comprised of a 100-ohm-reactance capacitor in parallel with a 100-ohm resistor?

C. 71 ohms at an angle of -45 degrees

~~

E5C08 (B)

In polar coordinates, what is the impedance of a network comprised of a 300-ohm-reactance inductor in series with a 400-ohm resistor?

B. 500 ohms at an angle of 37 degrees

~~

E5C09 (A)

When using rectangular coordinates to graph the impedance of a circuit, what does the horizontal axis represent?

A. The voltage or current associated with the resistive component

~~

E5C10 (B)

When using rectangular coordinates to graph the impedance of a circuit, what does the vertical axis represent?

B. The voltage or current associated with the reactive component

~~

E5C11 (C)

What do the two numbers represent that are used to define a point on a graph using rectangular coordinates?

C. The coordinate values along the horizontal and vertical axes

~~

E5C12 (D)

If you plot the impedance of a circuit using the rectangular coordinate system and find the impedance point falls on the right side of the graph on the horizontal line, what do you know about the circuit?

D. It is equivalent to a pure resistance

~~

E5C13 (D)

What coordinate system is often used to display the resistive, inductive, and/or capacitive reactance components of an impedance?

D. Rectangular coordinates

~~

E5C14 (D)

What coordinate system is often used to display the phase angle of a circuit containing resistance, inductive and/or capacitive reactance?

D. Polar coordinates

~~

E5C15 (A)

In polar coordinates, what is the impedance of a circuit of 100 -j100 ohms impedance?

A. 141 ohms at an angle of -45 degrees

~~

E5C16 (B)

In polar coordinates, what is the impedance of a circuit that has an admittance of 7.09 millisiemens at 45 degrees?

B. 141 ohms at an angle of -45 degrees

~~

E5C17 (C)

In rectangular coordinates, what is the impedance of a circuit that has an admittance of 5 millisiemens at -30 degrees?

C. 173 + j100 ohms

~~

E5C18 (B)

In polar coordinates, what is the impedance of a series circuit consisting of a resistance of 4 ohms, an inductive reactance of 4 ohms, and a capacitive reactance of 1 ohm?

B. 5 ohms at an angle of 37 degrees

~~

E5C19 (B)

Which point on Figure E5-2 best represents that impedance of a series circuit consisting of a 400 ohm resistor and a 38 picofarad capacitor at 14 MHz?

B. Point 4

~~

E5C20 (B)

Which point in Figure E5-2 best represents the impedance of a series circuit consisting of a 300 ohm resistor and an 18 microhenry inductor at 3.505 MHz?

B. Point 3

~~

E5C21 (A)

Which point on Figure E5-2 best represents the impedance of a series circuit consisting of a 300 ohm resistor and a 19 picofarad capacitor at 21.200 MHz?

A. Point 1

~~

E5C22 (A)

In rectangular coordinates, what is the impedance of a network comprised of a 10-microhenry inductor in series with a 40-ohm resistor at 500 MHz?

A. $40 + j31,400$

~~

E5C23 (D)

Which point on Figure E5-2 best represents the impedance of a series circuit consisting of a 300-ohm resistor, a 0.64-microhenry inductor and an 85-picofarad capacitor at 24.900 MHz?

D. Point 8

~~

E5D AC and RF energy in real circuits: skin effect; electrostatic and electromagnetic fields; reactive power; power factor; coordinate systems

E5D01 (A)

What is the result of skin effect?

A. As frequency increases, RF current flows in a thinner layer of the conductor, closer to the surface

~~

E5D02 (C)

Why is the resistance of a conductor different for RF currents than for direct currents?

C. Because of skin effect

~~

E5D03 (C)

What device is used to store electrical energy in an electrostatic field?

C. A capacitor

~~

E5D04 (B)

What unit measures electrical energy stored in an electrostatic field?

B. Joule

~~

E5D05 (B)

What is a magnetic field?

B. The region surrounding a magnet through which a magnetic force acts

~~

E5D06 (D)

In what direction is the magnetic field oriented about a conductor in relation to the direction of electron flow?

D. In a direction determined by the left-hand rule

~~

E5D07 (D)

What determines the strength of a magnetic field around a conductor?

D. The amount of current

~~

E5D08 (B)

What is the term for energy that is stored in an electromagnetic or electrostatic field?

B. Potential energy

~~

E5D09 (D)

What is the term for an out-of-phase, nonproductive power associated with inductors and capacitors?

D. Reactive power

~~

E5D10 (B)

In a circuit that has both inductors and capacitors, what happens to reactive power?

B. It is repeatedly exchanged between the associated magnetic and electric fields, but is not dissipated

~~

E5D11 (A)

How can the true power be determined in an AC circuit where the voltage and current are out of phase?

A. By multiplying the apparent power times the power factor

~~

E5D12 (C)

What is the power factor of an R-L circuit having a 60 degree phase angle between the voltage and the current?

C. 0.5

~~

E5D13 (B)

How many watts are consumed in a circuit having a power factor of 0.2 if the input is 100-V AC at 4 amperes?

B. 80 watts

~~

E5D14 (B)

How much power is consumed in a circuit consisting of a 100 ohm resistor in series with a 100 ohm inductive reactance drawing 1 ampere?

B. 100 Watts

~~

E5D15 (A)

What is reactive power?

A. Wattless, nonproductive power

~~

E5D16 (D)

What is the power factor of an RL circuit having a 45 degree phase angle between the voltage and the current?

D. 0.707

~~

E5D17 (C) was [E5H14]

What is the power factor of an RL circuit having a 30 degree phase angle between the voltage and the current?

C. 0.866

~~

E5D18 (D)

How many watts are consumed in a circuit having a power factor of 0.6 if the input is 200V AC at 5 amperes?

D. 600 watts

~~

E5D19 (B)

How many watts are consumed in a circuit having a power factor of 0.71 if the apparent power is 500 watts?

B. 355 W

~~

SUBELEMENT E6 -- CIRCUIT COMPONENTS [6 Exam Questions -- 6 Groups]

E6A Semiconductor materials and devices: semiconductor materials (germanium, silicon, P-type, N-type); transistor types: NPN, PNP, junction, power; field-effect transistors: enhancement mode; depletion mode; MOS; CMOS; N-channel; P-channel

E6A01 (C)

In what application is gallium arsenide used as a semiconductor material in preference to germanium or silicon?

C. At microwave frequencies

~~

E6A02 (A)

What type of semiconductor material contains more free electrons than pure germanium or silicon crystals?

A. N-type

~~

E6A03 (C)

What are the majority charge carriers in P-type semiconductor material?

C. Holes

~~

E6A04 (C)

What is the name given to an impurity atom that adds holes to a semiconductor crystal structure?

C. Acceptor impurity

~~

E6A05 (C)

What is the alpha of a bipolar junction transistor?

C. The change of collector current with respect to emitter current

~~

E6A06 (B)

What is meant by the beta of a bipolar junction transistor?

B. The change in collector current with respect to base current

~~

E6A07 (A)

In Figure E6-1, what is the schematic symbol for a PNP transistor?

A. 1

~~

E6A08 (D)

What term indicates the frequency at which a transistor grounded base current gain has decreased to 0.7 of the gain obtainable at 1 kHz?

D. Alpha cutoff frequency

~~

E6A09 (A)

What is a depletion-mode FET?

A. An FET that exhibits a current flow between source and drain when no gate voltage is applied

~~

E6A10 (B) {Was E6A09}

In Figure E6-2, what is the schematic symbol for an N-channel dual-gate MOSFET?

B. 4

~~

E6A11 (A)

In Figure E6-2, what is the schematic symbol for a P-channel junction FET?

A. 1

~~

E6A12 (D)

Why do many MOSFET devices have built-in gate-protective Zener diodes?

D. To reduce the chance of the gate insulation being punctured by static discharges or excessive voltages

~~

E6A13 (C)

What do the initials CMOS stand for?

C. Complementary metal-oxide semiconductor

~~

E6A14 (C)

How does DC input impedance at the gate of a field-effect transistor compare with the DC input impedance of a bipolar transistor?

C. An FET has high input impedance; a bipolar transistor has low input impedance

~~

E6A15 (B)

What two elements widely used in semiconductor devices exhibit both metallic and nonmetallic characteristics?

B. Silicon and germanium

~~

E6A16 (B)

What type of semiconductor material contains fewer free electrons than pure germanium or silicon crystals?

B. P-type

~~

E6A17 (B)

What are the majority charge carriers in N-type semiconductor material?

B. Free electrons

~~

E6A18 (D)

What are the names of the three terminals of a field-effect transistor?

D. Gate, drain, source

~~

E6B Semiconductor diodes

E6B01 (B)

What is the principal characteristic of a Zener diode?

B. A constant voltage under conditions of varying current

~~

E6B02 (C)

What is the principal characteristic of a tunnel diode?

C. A negative resistance region

~~

E6B03 (D)

What is an important characteristic of a Schottky Barrier diode as compared to an ordinary silicon diode when used as a power supply rectifier?

D. Less forward voltage drop

~~

E6B04 (C)

What special type of diode is capable of both amplification and oscillation?

C. Tunnel

~~

E6B05 (A)

What type of semiconductor device varies its internal capacitance as the voltage applied to its terminals varies?

A. Varactor diode

~~

E6B06 (D)

In Figure E6-3, what is the schematic symbol for a varactor diode?

D. 1

~~

E6B07 (D)

What is a common use of a hot-carrier diode?

D. As a VHF / UHF mixer or detector

~~

E6B08 (B)

What limits the maximum forward current rating in a junction diode?

B. Junction temperature

~~

E6B09 (A)

Which of the following describes a type of semiconductor diode?

A. Metal-semiconductor junction

~~

E6B10 (C)

What is a common use for point contact diodes?

C. As an RF detector

~~

E6B11 (B)

In Figure E6-3, what is the schematic symbol for a light-emitting diode?

B. 5

~~

E6B12 (D)

How are junction diodes rated?

D. Maximum forward current and PIV

~~

E6B13 (C)

What is one common use for PIN diodes?

C. As an RF switch

~~

E6B14 (B)

What type of bias is required for an LED to produce luminescence?

B. Forward bias

~~

E6C Integrated circuits: TTL digital integrated circuits; CMOS digital integrated circuits; gates

E6C01 (C)

What is the recommended power supply voltage for TTL series integrated circuits?

C. 5 volts

~~

E6C02 (A)

What logic state do the inputs of a TTL device assume if they are left open?

A. A logic-high state

~~

E6C03 (A)

What level of input voltage is a logic "high" in a TTL device operating with a positive 5-volt power supply?

A. 2.0 to 5.5 volts

~~

E6C04 (C)

What level of input voltage is a logic "low" in a TTL device operating with a positive 5-volt power-supply?

C. 0.0 to 0.8 volts

~~

E6C05 (D)

Which of the following is an advantage of CMOS logic devices over TTL devices?

D. Lower power consumption

~~

E6C06 (C)

Why do CMOS digital integrated circuits have high immunity to noise on the input signal or power supply?

C. The input switching threshold is about one-half the power supply voltage

~~

E6C07 (A)

In Figure E6-5, what is the schematic symbol for an AND gate?

A. 1

~~

E6C08 (B)

In Figure E6-5, what is the schematic symbol for a NAND gate?

B. 2

~~

E6C09 (B)

In Figure E6-5, what is the schematic symbol for an OR gate?

B. 3

~~

E6C10 (D)

In Figure E6-5, what is the schematic symbol for a NOR gate?

D. 4

~~

E6C11 (C)

In Figure E6-5, what is the schematic symbol for the NOT operation (inverter)?

C. 5

~~

E6D Optical devices and toroids: vidicon and cathode-ray tube devices; charge-coupled devices (CCDs); liquid crystal displays (LCDs); toroids: permeability, core material, selecting, winding

E6D01 (D)

How is the electron beam deflected in a vidicon?

D. By varying electromagnetic fields

~~

E6D02 (D)

What is cathode ray tube (CRT) persistence?

D. The length of time the image remains on the screen after the beam is turned off

~~

E6D03 (A)

If a cathode ray tube (CRT) is designed to operate with an anode voltage of 25,000 volts, what will happen if the anode voltage is increased to 35,000 volts?

A. The image size will decrease

~~

E6D04 (B)

Exceeding what design rating can cause a cathode ray tube (CRT) to generate X-rays?

B. The anode voltage

~~

E6D05 (C)

Which of the following is true of a charge-coupled device (CCD)?

C. It samples an analog signal and passes it in stages from the input to the output

~~

E6D06 (A)

What function does a charge-coupled device (CCD) serve in a modern video camera?

A. It stores photogenerated charges as signals corresponding to pixels

~~

E6D07 (B)

What is a liquid-crystal display (LCD)?

B. A display that uses a crystalline liquid to change the way light is refracted

~~

E6D08 (D)

What material property determines the inductance of a toroidal inductor with a 10-turn winding?

D. Core permeability

~~

E6D09 (B)

What is the usable frequency range of inductors that use toroidal cores, assuming a correct selection of core material for the frequency being used?

B. From less than 20 Hz to approximately 300 MHz

~~

E6D10 (B)

What is one important reason for using powdered-iron toroids rather than ferrite toroids in an inductor?

B. Powdered-iron toroids generally have better temperature stability

~~

E6D11 (C)

What devices are commonly used as VHF and UHF parasitic suppressors at the input and output terminals of transistorized HF amplifiers?

C. Ferrite beads

~~

E6D12 (A)

What is a primary advantage of using a toroidal core instead of a solenoidal core in an inductor?

A. Toroidal cores contain most of the magnetic field within the core material

~~

E6D13 (C)

How many turns will be required to produce a 1-mH inductor using a ferrite toroidal core that has an inductance index (A L) value of 523 millihenrys/1000 turns?

C. 43 turns

~~

E6D14 (A)

How many turns will be required to produce a 5-microhenry inductor using a powdered-iron toroidal core that has an inductance index (A L) value of 40 microhenrys/100 turns?

A. 35 turns

~~

E6D15 (D)

What type of CRT deflection is better when high-frequency waves are to be displayed on the screen?

D. Electrostatic

~~

E6D16 (C)

Which is NOT true of a charge-coupled device (CCD)?

C. It is commonly used as an analog-to-digital converter

~~

E6D17 (A)

What is the principle advantage of liquid-crystal display (LCD) devices over other types of display devices?

A. They consume less power

~~

E6D18 (C)

What is one reason for using ferrite toroids rather than powdered-iron toroids in an inductor?

C. Ferrite toroids generally require fewer turns to produce a given inductance value

~~

E6E Piezoelectric crystals and MMICS: quartz crystals (as used in oscillators and filters); monolithic amplifiers (MMICs)

E6E01 (B)

Which of these filter bandwidths would be a good choice for use in a SSB radiotelephone transmitter?

B. 2.4 kHz at -6 dB

~~

E6E02 (C)

Which of these filter bandwidths would be a good choice for use with standard double-sideband AM transmissions?

C. 6 kHz at -6 dB

~~

E6E03 (D)

What is a crystal lattice filter?

D. A filter with narrow bandwidth and steep skirts made using quartz crystals

~~

E6E04 (D)

What technique is used to construct low-cost, high-performance crystal ladder filters?

D. Measure crystal frequencies and carefully select units with a frequency variation of less than 10% of the desired filter bandwidth

~~

E6E05 (A)

Which of the following factors has the greatest effect in helping determine the bandwidth and response shape of a crystal ladder filter?

A. The relative frequencies of the individual crystals

~~

E6E06 (A)

What is one aspect of the piezoelectric effect?

A. Physical deformation of a crystal by the application of a voltage

~~

E6E07 (A)

What is the characteristic impedance of circuits in which almost all MMICs are designed to work?

A. 50 ohms

E6E08 (B)

What is the typical noise figure of a monolithic microwave integrated circuit (MMIC) amplifier?

B. Approximately 3.5 to 6 dB

~~

E6E09 (D)

What type of amplifier device consists of a small pill-type package with an input lead, an output lead and 2 ground leads?

D. A monolithic microwave integrated circuit (MMIC)

~~

E6E10 (B)

What typical construction technique is used when building an amplifier for the microwave bands containing a monolithic microwave integrated circuit (MMIC)?

B. Microstrip construction

~~

E6E11 (A)

How is the operating bias voltage normally supplied to the most common type of monolithic microwave integrated circuit (MMIC)?

A. Through a resistor and/or RF choke connected to the amplifier output lead

~~

E6E12 (B)

What supply voltage do monolithic microwave integrated circuits (MMIC) amplifiers typically require?

B. 12 volts DC

~~

E6E13 (C)

What is the most common package for inexpensive monolithic microwave integrated circuit (MMIC) amplifiers?

C. Plastic packages

~~

E6F Optical components and power systems: photoconductive principles and effects, photovoltaic systems, optical couplers, optical sensors, and optoisolators

E6F01 (B)

What is photoconductivity?

B. The increased conductivity of an illuminated semiconductor

~~

E6F02 (A)

What happens to the conductivity of a photoconductive material when light shines on it?

A. It increases

~~

E6F03 (D)

What is the most common configuration for an optocoupler?

D. An LED and a phototransistor

~~

E6F04 (A)

Which of the following is an optoisolator?

A. An LED and a phototransistor

~~

E6F05 (B)

What is an optical shaft encoder?

B. An array of optocouplers whose light transmission path is controlled by a rotating wheel

~~

E6F06 (D)

What characteristic of a crystalline solid will photoconductivity change?

D. The resistance

~~

E6F07 (C)

Which material will exhibit the greatest photoconductive effect when illuminated by visible light?

C. Cadmium sulfide

~~

E6F08 (B)

Which material will exhibit the greatest photoconductive effect when illuminated by infrared light?

B. Lead sulfide

~~

E6F09 (A)

Which of the following materials is affected the most by photoconductivity?

A. A crystalline semiconductor

~~

E6F10 (B)

What characteristic of optoisolators is often used in power supplies?

B. They have very high impedance between the light source and the phototransistor

~~

E6F11 (C)

What characteristic of optoisolators makes them suitable for use with a triac to form the solid-state equivalent of a mechanical relay for a 120 V AC household circuit?

C. Optoisolators provide a very high degree of electrical isolation between a control circuit and a power circuit

~~

E6F12 (D)

Which of the following types of photovoltaic cell has the highest efficiency?

D. Gallium arsenide

~~

E6F13 (B)

What is the most common type of photovoltaic cell used for electrical power generation?

B. Silicon

~~

E6F14 (B)

B) Which of the following is the approximate open-circuit voltage produced by a fully-illuminated silicon photovoltaic cell?

B. 0.5 V

~~

E6F15 (C)

What absorbs the energy from light falling on a photovoltaic cell?

C. Electrons

~~

SUBELEMENT E7 -- PRACTICAL CIRCUITS [8 Exam Questions -- 8 Groups]

E7 Digital circuits: digital circuit principles and logic circuits: classes of logic elements; positive and negative logic; frequency dividers; truth tables

E7A01 (C)

What is a bistable circuit?

C. A flip-flop

~~

E7A02 (C)

How many output level changes are obtained for every two trigger pulses applied to the input of a "T" flip-flop circuit?

C. Two

~~

E7A03 (B)

Which of the following can divide the frequency of pulse train by 2?

B. A flip-flop

~~

E7A04 (B)

How many flip-flops are required to divide a signal frequency by 4?

B. 2

~~

E7A05 (D)

Which of the following is a circuit that continuously alternates between two unstable states without an external clock?

D. Astable Multivibrator

~~

E7A06 (A)

What is a characteristic of a monostable multivibrator?

A. It switches momentarily to the opposite binary state and then returns, after a set time, to its original state

~~

E7A07 (B)

What logical operation does an AND gate perform?

B. It produces a logic "1" at its output only if all inputs are logic "1"

~~

E7A08 (D)

What logical operation does a NAND gate perform?

D. It produces a logic "0" at its output only when all inputs are logic "1"

~~

E7A09 (A)

What logical operation does an OR gate perform?

A. It produces a logic "1" at its output if any or all inputs are logic "1"

~~

E7A10 (C)

What logical operation does a NOR gate perform?

C. It produces a logic "0" at its output if any or all inputs are logic "1"

~~

E7A11 (C)

What is a truth table?

C. A list of inputs and corresponding outputs for a digital device

~~

E7A12 (D)

What is the name for logic which represents a logic "1" as a high voltage?

D. Positive Logic

~~

E7A13 (C)

What is the name for logic which represents a logic "0" as a high voltage?

C. Negative logic

~~

E7B Amplifiers: Class of operation; vacuum tube and solid-state circuits; distortion and intermodulation; spurious and parasitic suppression; microwave amplifiers

E7B01 (A)

For what portion of a signal cycle does a Class AB amplifier operate?

A. More than 180 degrees but less than 360 degrees

~~

E7B02 (C)

Which class of amplifier, of the types shown, provides the highest efficiency?

C. Class C

~~

E7B03 (A)

Where on the load line of a Class A common emitter amplifier would bias normally be set?

A. Approximately half-way between saturation and cutoff

~~

E7B04 (C)

What can be done to prevent unwanted oscillations in a power amplifier?

C. Install parasitic suppressors and/or neutralize the stage

~~

E7B05 (B)

Which of the following amplifier types reduces or eliminates even-order harmonics?

B. Push-pull

~~

E7B06 (D)

Which of the following is a likely result when a Class C rather than a class AB amplifier is used to amplify a single-sideband phone signal?

D. The signal may become distorted and occupy excessive bandwidth

~~

E7B07 (C)

How can a vacuum-tube power amplifier be neutralized?

C. By feeding back an out-of-phase component of the output to the input

~~

E7B08 (D)

Which of the following describes how the loading and tuning capacitors are to be adjusted when tuning a vacuum tube RF power amplifier that employs a pi-network output circuit?

D. The tuning capacitor is adjusted for minimum plate current, while the loading capacitor is adjusted for maximum permissible plate current

~~

E7B09 (B)

In Figure E7-1, what is the purpose of R1 and R2?

B. Fixed bias

~~

E7B10 (D)

In Figure E7-1, what is the purpose of R3?

D. Self bias

~~

E7B11 (C)

What type of circuit is shown in Figure E7-1?

C. Common emitter amplifier

~~

E7B12 (A)

In Figure E7-2, what is the purpose of R?

A. Emitter load

~~

E7B13 (A)

In Figure E7-2, what is the purpose of C2?

A. Output coupling

~~

E7B14 (C)

What is one way to prevent thermal runaway in a transistor amplifier?

C. Use degenerative emitter feedback

~~

E7B15 (A)

What is the effect of intermodulation products in a linear power amplifier?

A. Transmission of spurious signals

~~

E7B16 (A)

Why are third-order intermodulation distortion products of particular concern in linear power amplifiers?

A. Because they are relatively close in frequency to the desired signal

~~

E7B17 (C)

Which of the following is a characteristic of a grounded-grid amplifier?

C. Low input impedance

~~

E7B18 (D)

What is a klystron?

D. A VHF, UHF, or microwave vacuum tube that uses velocity modulation

~~

E7B19 (B)

What is a parametric amplifier?

B. A low-noise VHF or UHF amplifier relying on varying reactance for amplification

~~

E7B20 (A)

Which of the following devices is generally best suited for UHF or microwave power amplifier applications?

A. FET

~~

E7C Filters and matching networks: filters and impedance matching networks: types of networks; types of filters; filter applications; filter characteristics; impedance matching; DSP filtering

E7C01 (D)

How are the capacitors and inductors of a low-pass filter Pi-network arranged between the network's input and output?

D. A capacitor is in parallel with the input, another capacitor is in parallel with the output, and an inductor is in series between the two

~~

E7C02 (C)

A T-network with series capacitors and a parallel (shunt) inductor has which of the following properties?

C. It transforms impedance and is a high-pass filter

~~

E7C03 (A)

What advantage does a Pi-L-network have over a Pi-network for impedance matching between the final amplifier of a vacuum-tube type transmitter and an antenna?

A. Greater harmonic suppression

~~

E7C04 (C)

How does a network transform a complex impedance to a resistive impedance?

C. It cancels the reactive part of an impedance and transforms the resistive part to the desired value

~~

E7C05 (D)

Which filter type is described as having ripple in the passband and a sharp cutoff?

D. A Chebyshev filter

~~

E7C06 (C)

What are the distinguishing features of an elliptical filter?

C. Extremely sharp cutoff, with one or more infinitely deep notches in the stop band

~~

E7C07 (B)

What kind of audio filter would you use to attenuate an interfering carrier signal while receiving an SSB transmission?

B. A notch filter

~~

E7C08 (A)

What kind of digital signal processing audio filter might be used to remove unwanted noise from a received SSB signal?

A. An adaptive filter

~~

E7C09 (C)

What type of digital signal processing filter might be used in generating an SSB signal?

C. A Hilbert-transform filter

~~

E7C10 (B)

Which of the following filters would be the best choice for use in a 2-meter repeater duplexer?

B. A cavity filter

~~

E7C11 (D)

Which of the following is the common name for a filter network which is equivalent to two L networks back-to-back?

D. Pi

~~

E7C12 (B)

What is a Pi-L network, as used when matching a vacuum-tube final amplifier to a 50-ohm unbalanced output?

B. A network consisting of two series inductors and two shunt capacitors

~~

E7C13 (A)

What is one advantage of a Pi matching network over an L matching network?

A. Q of Pi networks can be varied depending on the component values chosen

~~

E7C14 (C)

Which of these modes is most affected by non-linear phase response in a receiver IF filter?

C. Digital

~~

E7D Power supplies and voltage regulators

E7D01 (D)

What is one characteristic of a linear electronic voltage regulator?

D. The conduction of a control element is varied to maintain a constant output voltage

~~

E7D02 (C)

What is one characteristic of a switching electronic voltage regulator?

C. The control device's duty cycle is controlled to produce a constant average output voltage

~~

E7D03 (A)

What device is typically used as a stable reference voltage in a linear voltage regulator?

A. A Zener diode

~~

E7D04 (B)

Which of the following types of linear regulator makes the most efficient use of the primary power source?

B. A series regulator

~~

E7D05 (D)

Which of the following types of linear voltage regulator places a constant load on the unregulated voltage source?

D. A shunt regulator

~~

E7D06 (C)

What is the purpose of Q1 in the circuit shown in Figure E7-3?

C. It increases the current-handling capability of the regulator

~~

E7D07 (A)

What is the purpose of C2 in the circuit shown in Figure E7-3?

A. It bypasses hum around D1

~~

E7D08 (C)

What type of circuit is shown in Figure E7-3?

C. Linear voltage regulator

~~

E7D09 (D)

What is the purpose of C1 in the circuit shown in Figure E7-3?

D. It filters the supply voltage

~~

E7D10 (A)

What is the purpose of C3 in the circuit shown in Figure E7-3?

A. It prevents self-oscillation

~~

E7D11 (C)

What is the purpose of R1 in the circuit shown in Figure E7-3?

C. It supplies current to D1

~~

E7D12 (D)

What is the purpose of R2 in the circuit shown in Figure E7-3?

D. It provides a constant minimum load for Q1

~~

E7D13 (B)

What is the purpose of D1 in the circuit shown in Figure E7-3?

B. To provide a voltage reference

~~

E7D14 (C)

What is one purpose of a "bleeder" resistor in a conventional (unregulated) power supply?

C. To improve output voltage regulation

~~

E7D15 (D)

What is the purpose of a "step-start" circuit in a high-voltage power supply?

D. To allow the filter capacitors to charge gradually

~~

E7D16 (D)

When several electrolytic filter capacitors are connected in series to increase the operating voltage of a power supply filter circuit, why should resistors be connected across each capacitor?

- A. To equalize, as much as possible, the voltage drop across each capacitor
- B. To provide a safety bleeder to discharge the capacitors when the supply is off
- C. To provide a minimum load current to reduce voltage excursions at light loads
- D. All of these answers are correct

~~

E7D17 (C)

What is the primary reason that a high-frequency inverter type high-voltage power supply can be both less expensive and lighter in weight than a conventional power supply?

- C. The high frequency inverter design uses much smaller transformers and filter components for an equivalent power output

~~

E7E Modulation and demodulation: reactance, phase and balanced modulators; detectors; mixer stages; DSP modulation and demodulation; software defined radio systems

E7E01 (B)

Which of the following can be used to generate FM-phone emissions?

- B. A reactance modulator on the oscillator

~~

E7E02 (D)

What is the function of a reactance modulator?

- D. To produce PM signals by using an electrically variable inductance or capacitance

~~

E7E03 (C)

What is the fundamental principle of a phase modulator?

- C. It varies the tuning of an amplifier tank circuit to produce PM signals

~~

E7E04 (A)

What is one way a single-sideband phone signal can be generated?

- A. By using a balanced modulator followed by a filter

~~

E7E05 (D)

What circuit is added to an FM transmitter to proportionally attenuate the lower audio frequencies?

- D. A pre-emphasis network

~~

E7E06 (A)

What circuit is added to an FM receiver to restore attenuated lower audio frequencies?

- A. A de-emphasis network

~~

E7E07 (D)

What is one result of the process of mixing two signals?

D. The creation of new signals at the sum and difference frequencies

~~

E7E08 (C)

What are the principal frequencies that appear at the output of a mixer circuit?

C. The original frequencies, and the sum and difference frequencies

~~

E7E09 (A)

What occurs when an excessive amount of signal energy reaches a mixer circuit?

A. Spurious mixer products are generated

~~

E7E10 (B)

What is the process of detection?

B. The recovery of information from a modulated RF signal

~~

E7E11 (A)

How does a diode detector function?

A. By rectification and filtering of RF signals

~~

E7E12 (C)

Which of the following types of detector is well suited for demodulating SSB signals?

C. Product detector

~~

E7E13 (D)

What is a frequency discriminator?

D. A circuit for detecting FM signals

~~

E7E14 (D)

Which of the following describes a common means of generating a SSB signal when using digital signal processing?

D. The phasing or quadrature method

E7E15 (C)

What is meant by "direct conversion" when referring to a software defined receiver?

C. Incoming RF is mixed to "baseband" for analog-to-digital conversion and subsequent processing

~~

E7F Frequency markers and counters: frequency divider circuits; frequency marker generators; frequency counters

E7F01 (D)

What is the purpose of a prescaler circuit?

D. It divides a higher frequency signal so a low-frequency counter can display the operating frequency

E7F02 (B)

Which of the following would be used to reduce a signal's frequency by a factor of ten?

B. A prescaler

~~

E7F03 (A)

What is the function of a decade counter digital IC?

A. It produces one output pulse for every ten input pulses

~~

E7F04 (C)

What additional circuitry must be added to a 100-kHz crystal-controlled marker generator so as to provide markers at 50 and 25 kHz?

C. Two flip-flops

~~

E7F05 (B)

Which of the following circuits can be combined to produce a 100 kHz fundamental signal with harmonics at 100 kHz intervals?

B. A 1 MHz oscillator and a decade counter

~~

E7F06 (D)

Which of these choices best describes a crystal marker generator?

D. A crystal-controlled oscillator that generates a series of reference signals at known frequency intervals

~~

E7F07 (D)

Which type of circuit would be a good choice for generating a series of harmonically related receiver calibration signals?

D. A crystal oscillator followed by a frequency divider

~~

E7F08 (C)

What is one purpose of a marker generator?

C. To provide a means of calibrating a receiver's frequency settings

~~

E7F09 (A)

What determines the accuracy of a frequency counter?

A. The accuracy of the time base

~~

E7F10 (C)

How does a conventional frequency counter determine the frequency of a signal?

C. It counts the number of input pulses occurring within a specific period of time

E7F11 (A)

What is the purpose of a frequency counter?

A. To provide a digital representation of the frequency of a signal

~~

E7F12 (B)

What alternate method of determining frequency, other than by directly counting input pulses, is used by some frequency counters?

B. Period measurement

~~

E7F13 (C)

What is an advantage of a period-measuring frequency counter over a direct-count type?

C. It provides improved resolution of signals within a comparable time period

~~

E7G Active filters and op-amps: active audio filters; characteristics; basic circuit design; operational amplifiers

E7G01 (B)

What determines the gain and frequency characteristics of an op-amp RC active filter?

B. The values of capacitors and resistors external to the op-amp

~~

E7G02 (C)

What causes ringing in a filter?

C. The frequency and phase response of the filter

~~

E7G03 (D)

What are the advantages of using an op-amp instead of LC elements in an audio filter?

D. Op-amps exhibit gain rather than insertion loss

~~

E7G04 (C)

Which of the following capacitor types is best suited for use in high-stability op-amp RC active filter circuits?

C. Polystyrene

~~

E7G05 (A)

How can unwanted ringing and audio instability be prevented in a multi-section op-amp RC audio filter circuit?

A. Restrict both gain and Q

~~

E7G06 (A)

What steps are typically followed when selecting the external components for an op-amp RC active filter?

A. Standard capacitor values are chosen first, the resistances are calculated, and resistors of the nearest standard value are used

~~

E7G07 (D)

Which of the following is the most appropriate use of an op-amp RC active filter?

D. As an audio receiving filter

~~

E7G08 (D)

Which of the following is a type of active op-amp filter circuit?

D. Sallen-Key

~~

E7G09 (C)

What voltage gain can be expected from the circuit in Figure E7-4 when R_1 is 10 ohms and R_F is 470 ohms?

C. 47

~~

E7G10 (D)

How does the gain of a theoretically ideal operational amplifier vary with frequency?

D. It does not vary with frequency

~~

E7G11 (D)

What will be the output voltage of the circuit shown in Figure E7-4 if R_1 is 1000 ohms, R_F is 10,000 ohms, and 0.23 volts is applied to the input?

D. -2.3 volts

~~

E7G12 (C)

What voltage gain can be expected from the circuit in Figure E7-4 when R_1 is 1800 ohms and R_F is 68 kilohms?

C. 38

~~

E7G13 (B)

What voltage gain can be expected from the circuit in Figure E7-4 when R_1 is 3300 ohms and R_F is 47 kilohms?

B. 14

~~

E7G14 (A)

What is an operational amplifier?

A. A high-gain, direct-coupled differential amplifier whose characteristics are determined by components external to the amplifier

~~

E7G15 (C)

What is meant by the term "op-amp input-offset voltage"?

C. The potential between the amplifier input terminals of the op-amp in a closed-loop condition

~~

E7G16 (D)

What is the typical input impedance of an integrated circuit op-amp?

D. Very high

~~

E7G17 (A)

What is the typical output impedance of an integrated circuit op-amp?

A. Very low

~~

E7H Oscillators and signal sources: types of oscillators;
synthesizers and phase-locked loops; direct digital synthesizers

E7H01 (D)

What are three major oscillator circuits often used in Amateur Radio equipment?

D. Colpitts, Hartley and Pierce

~~

E7H02 (C)

What condition must exist for a circuit to oscillate?

C. It must have a positive feedback loop with a gain greater than 1

~~

E7H03 (A)

How is positive feedback supplied in a Hartley oscillator?

A. Through a tapped coil

~~

E7H04 (C)

How is positive feedback supplied in a Colpitts oscillator?

C. Through a capacitive divider

~~

E7H05 (D)

How is positive feedback supplied in a Pierce oscillator?

D. Through a quartz crystal

~~

E7H06 (B)

Which type of oscillator circuits are commonly used in VFOs?

B. Colpitts and Hartley

~~

E7H07(C)

What is a magnetron oscillator?

C. A UHF or microwave oscillator consisting of a diode vacuum tube with a specially shaped anode, surrounded by an external magnet

~~

E7H08 (A)

What is a Gunn diode oscillator?

A. An oscillator based on the negative resistance properties of properly-doped semiconductors

~~

E7H09 (C)

What type of frequency synthesizer circuit uses a stable voltage-controlled oscillator, programmable divider, phase detector, loop filter and a reference frequency source?

C. A phase locked loop synthesizer

~~

E7H10 (A)

What type of frequency synthesizer circuit uses a phase accumulator, lookup table, digital to analog converter and a low-pass anti-alias filter?

A. A direct digital synthesizer

~~

E7H11 (B)

What information is contained in the lookup table of a direct digital frequency synthesizer?

B. The amplitude values that represent a sine-wave output

~~

E7H12 (C)

What are the major spectral impurity components of direct digital synthesizers?

C. Spurs at discrete frequencies

~~

E7H13 (D)

Which of these circuits would be classified as a principal component of a direct digital synthesizer (DDS)?

D. Phase accumulator

~~

E7H14 (C)

What circuit is often used in conjunction with a direct digital synthesizer (DDS) to expand the available tuning range?

C. Phase locked loop

~~

E7H15 (A)

What is the capture range of a phase-locked loop circuit?

A. The frequency range over which the circuit can lock

~~

E7H16 (C)

What is a phase-locked loop circuit?

C. An electronic servo loop consisting of a phase detector, a low-pass filter and voltage-controlled oscillator

~~

E7H17 (D)

Which of these functions can be performed by a phase-locked loop?

D. Frequency synthesis, FM demodulation

~~

E7H18 (B)

Why is a stable reference oscillator normally used as part of a phase locked loop (PLL) frequency synthesizer?

B. Any phase variations in the reference oscillator signal will produce phase noise in the synthesizer output

~~

E7H19 (C)

Why is a phase-locked loop often used as part of a variable frequency synthesizer for receivers and transmitters?

C. It makes it possible for a VFO to have the same degree of stability as a crystal oscillator

E7H20 (A)

What are the major spectral impurity components of phase-locked loop synthesizers?

A. Broadband noise

SUBELEMENT E8 -- SIGNALS AND EMISSIONS [4 Exam Questions -- 4 Groups]

E8A AC waveforms: sine, square, sawtooth and irregular waveforms; AC measurements; average and PEP of RF signals; pulse and digital signal waveforms

E8A01 (A)

What type of wave is made up of a sine wave plus all of its odd harmonics?

A. A square wave

~~

E8A02 (C)

What type of wave has a rise time significantly faster than its fall time (or vice versa)?

C. A sawtooth wave

~~

E8A03 (A)

What type of wave is made up of sine waves of a given fundamental frequency plus all its harmonics?

A. A sawtooth wave

~~

E8A04 (C)

What is the equivalent to the root-mean-square value of an AC voltage?

C. The DC voltage causing the same amount of heating in a resistor as the corresponding RMS AC voltage

~~

E8A05 (D)

What would be the most accurate way of measuring the RMS voltage of a complex waveform?

D. By measuring the heating effect in a known resistor

E8A06 (A)

What is the approximate ratio of PEP-to-average power in a typical voice-modulated single-sideband phone signal?

A. 2.5 to 1

~~

E8A07 (B)

What determines the PEP-to-average power ratio of a single-sideband phone signal?

B. The characteristics of the modulating signal

~~

E8A08 (A)

What is the period of a wave?

A. The time required to complete one cycle

~~

E8A09 (C)

What type of waveform is produced by human speech?

C. Irregular

~~

E8A10 (B)

Which of the following is a distinguishing characteristic of a pulse waveform?

B. Narrow bursts of energy separated by periods of no signal

~~

E8A11 (D)

What is one use for a pulse modulated signal?

D. Digital data transmission

~~

E8A12 (D)

What type of information can be conveyed using digital waveforms?

A. Human speech

B. Video signals

C. Data

D. All of these answers are correct

~~

E8A13 (C)

What is an advantage of using digital signals instead of analog signals to convey the same information?

C. Digital signals can be regenerated multiple times without error

~~

E8A14 (A)

Which of these methods is commonly used to convert analog signals to digital signals?

A. Sequential sampling

~~

E8A15 (B)

What would the waveform of a digital data stream signal look like on a conventional oscilloscope?

B. A series of pulses with varying patterns

E8B Modulation and demodulation: modulation methods; modulation index and deviation ratio; pulse modulation; frequency and time division multiplexing

E8B01 (D)

What is the term for the ratio between the frequency deviation of an RF carrier wave, and the modulating frequency of its corresponding FM-phone signal?

D. Modulation index

~~

E8B02 (D)

How does the modulation index of a phase-modulated emission vary with RF carrier frequency (the modulated frequency)?

D. It does not depend on the RF carrier frequency

~~

E8B03 (A)

What is the modulation index of an FM-phone signal having a maximum frequency deviation of 3000 Hz either side of the carrier frequency, when the modulating frequency is 1000 Hz?

A. 3

~~

E8B04 (B)

What is the modulation index of an FM-phone signal having a maximum carrier deviation of plus or minus 6 kHz when modulated with a 2-kHz modulating frequency?

B. 3

~~

8B05 (D)

What is the deviation ratio of an FM-phone signal having a maximum frequency swing of plus-or-minus 5 kHz and accepting a maximum modulation rate of 3 kHz?

D. 1.67

~~

E8B06 (A)

What is the deviation ratio of an FM-phone signal having a maximum frequency swing of plus or minus 7.5 kHz and accepting a maximum modulation frequency of 3.5 kHz?

A. 2.14

~~

E8B07 (A)

When using a pulse-width modulation system, why is the transmitter's peak power greater than its average power?

A. The signal duty cycle is less than 100%

~~

E8B08 (D)

What parameter does the modulating signal vary in a pulse-position modulation system?

D. The time at which each pulse occurs

~~

E8B09 (A)

How are the pulses of a pulse-modulated signal usually transmitted?

A. A pulse of relatively short duration is sent; a relatively long period of time separates each pulse

~~

E8B10 (B)

What is meant by deviation ratio?

B. The ratio of the maximum carrier frequency deviation to the highest audio modulating frequency

~~

E8B11 (C)

Which of these methods can be used to combine several separate analog information streams into a single analog radio frequency signal?

C. Frequency division multiplexing

~~

E8B12 (B)

Which of the following describes frequency division multiplexing?

B. Two or more information streams are merged into a "baseband", which then modulates the transmitter

~~

E8B13 (B)

What is time division multiplexing?

B. Two or more signals are arranged to share discrete time slots of a digital data transmission

~~

E8C Digital signals: digital communications modes; CW; information rate vs. bandwidth; spread-spectrum communications; modulation methods

E8C01 (D)

Which one of the following digital codes consists of elements having unequal length?

D. Morse code

~~

E8C02 (B)

What are some of the differences between the Baudot digital code and ASCII?

B. Baudot uses five data bits per character, ASCII uses seven; Baudot uses two characters as shift codes, ASCII has no shift code

~~

E8C03 (C)

What is one advantage of using the ASCII code for data communications?

C. It is possible to transmit both upper and lower case text

~~

***** E8C04 This question has been removed by the QPC

E8C05 (C)

What technique is used to minimize the bandwidth requirements of a PSK-31 signal?

C. Use of sinusoidal data pulses

~~

E8C06 (C)

What is the necessary bandwidth of a 13-WPM international Morse code transmission?

C. Approximately 52 Hz

~~

E8C07 (C)

What is the necessary bandwidth of a 170-hertz shift, 300-baud ASCII transmission?

C. 0.5 kHz

~~

E8C08 (A)

What is the necessary bandwidth of a 4800-Hz frequency shift, 9600-baud ASCII FM transmission?

A. 15.36 kHz

~~

E8C09 (D)

What term describes a wide-bandwidth communications system in which the transmitted carrier frequency varies according to some predetermined sequence?

D. Spread-spectrum communication

~~

E8C10 (A)

Which of these techniques causes a digital signal to appear as wide-band noise to a conventional receiver?

A. Spread-spectrum

~~

E8C11 (A)

What spread-spectrum communications technique alters the center frequency of a conventional carrier many times per second in accordance with a pseudo-random list of channels?

A. Frequency hopping

~~

E8C12 (B)

What spread-spectrum communications technique uses a high speed binary bit stream to shift the phase of an RF carrier?

B. Direct sequence

~~

E8C13 (D)

What makes spread-spectrum communications resistant to interference?

D. Only signals using the correct spreading sequence are received

~~

E8C14 (D)

What is the advantage of including a parity bit with an ASCII character stream?

D. Some types of errors can be detected

~~

E8C15 (B)

What is one advantage of using JT-65 coding?

B. Virtually perfect decoding of signals well below the noise

~~

E8D Waves, measurements, and RF grounding: peak-to-peak values, polarization; RF grounding

E8D01 (A) [was E8D02 edited]

What is the easiest voltage amplitude parameter to measure when viewing a pure sine wave signal on an oscilloscope?

A. Peak-to-peak voltage

~~

E8D02 (B)

What is the relationship between the peak-to-peak voltage and the peak voltage amplitude of a symmetrical waveform?

B. 2:1

~~

E8D03 (A)

What input-amplitude parameter is valuable in evaluating the signal-handling capability of a Class A amplifier?

A. Peak voltage

~~

E8D04 (B)

What is the PEP output of a transmitter that has a maximum peak of 30 volts to a 50-ohm load as observed on an oscilloscope?

B. 9 watts

~~

E8D05 (D)

If an RMS-reading AC voltmeter reads 65 volts on a sinusoidal waveform, what is the peak-to-peak voltage?

D. 184 volts

~~

E8D06 (B)

What is the advantage of using a peak-reading wattmeter to monitor the output of a SSB phone transmitter?

B. It gives a more accurate display of the PEP output when modulation is present

~~

E8D07 (C)

What is an electromagnetic wave?

C. A wave consisting of an electric field and a magnetic field oscillating at right angles to each other

~~

E8D08 (D)

Which of the following best describes electromagnetic waves traveling in free space?

D. Changing electric and magnetic fields propagate the energy

~~

E8D09 (B)

What is meant by circularly polarized electromagnetic waves?

B. Waves with a rotating electric field

~~

E8D10 (D)

What is the polarization of an electromagnetic wave if its magnetic field is parallel to the surface of the Earth?

D. Vertical

~~

E8D11 (A)

What is the polarization of an electromagnetic wave if its magnetic field is perpendicular to the surface of the Earth?

A. Horizontal

~~

E8D12 (A)

At approximately what speed do electromagnetic waves travel in free space?

A. 300 million meters per second

~~

E8D13 (D)

What type of meter should be used to monitor the output signal of a voice-modulated single-sideband transmitter to ensure you do not exceed the maximum allowable power?

D. A peak-reading wattmeter

E8D14 (A)

What is the average power dissipated by a 50-ohm resistive load during one complete RF cycle having a peak voltage of 35 volts?

A. 12.2 watts

~~

E8D15 (D)

If an RMS reading voltmeter reads 34 volts on a sinusoidal waveform, what is the peak voltage?

D. 48 volts

~~

E8D16 (B)

Which of the following is a typical value for the peak voltage at a common household electrical outlet?

B. 170 volts

~~

E8D17 (C)

Which of the following is a typical value for the peak-to-peak voltage at a common household electrical outlet?

C. 340 volts

~~

E8D18 (A)

Which of the following is a typical value for the RMS voltage at a common household electrical power outlet?

A. 120-V AC

~~

E8D19 (A)

What is the RMS value of a 340-volt peak-to-peak pure sine wave?

A. 120-V AC

~~

SUBELEMENT E9 -- ANTENNAS AND TRANSMISSION LINES [8 Exam Questions -- 8 Groups]

E9A Isotropic and gain antennas: definition; used as a standard for comparison; radiation pattern; basic antenna parameters: radiation resistance and reactance, gain, beamwidth, efficiency

E9A01 (C)

Which of the following describes an isotropic Antenna?

C. A theoretical antenna used as a reference for antenna gain

~~

E9A02 (B)

How much gain does a 1/2-wavelength dipole have compared to an isotropic antenna?

B. 2.15 dB

E9A03 (D)

Which of the following antennas has no gain in any direction?

D. Isotropic antenna

~~

E9A04 (A)

Why would one need to know the feed point impedance of an antenna?

A. To match impedances for maximum power transfer from a feed line

~~

E9A05 (B)

Which of the following factors determine the radiation resistance of an antenna?

B. Antenna height and conductor length/diameter ratio, and location of nearby conductive objects

~~

E9A06 (C)

What is the term for the ratio of the radiation resistance of an antenna to the total resistance of the system?

C. Antenna efficiency

~~

E9A07 (D)

What is included in the total resistance of an antenna system?

D. Radiation resistance plus ohmic resistance

~~

E9A08 (C)

What is a folded dipole antenna?

C. A dipole constructed from one wavelength of wire forming a very thin loop

~~

E9A09 (A)

What is meant by antenna gain?

A. The numerical ratio relating the radiated signal strength of an antenna in the direction of maximum radiation to that of a reference antenna

~~

E9A10 (B)

What is meant by antenna bandwidth?

B. The frequency range over which an antenna satisfies a performance requirement

~~

E9A11 (B)

How is antenna efficiency calculated?

B. (radiation resistance / total resistance) x 100%

~~

E9A12 (A)

How can the efficiency of an HF quarter-wave grounded vertical antenna be improved?

A. By installing a good radial system

~~

E9A13(C)

Which is the most important factor that determines ground losses for a ground-mounted vertical antenna operating in the 3-30 MHz range?

C. Soil conductivity

~~

E9A14 (A)

How much gain does an antenna have over a 1/2-wavelength dipole when it has 6 dB gain over an isotropic antenna?

A. 3.85 dB

~~

E9A15 (B)

How much gain does an antenna have over a 1/2-wavelength dipole when it has 12 dB gain over an isotropic antenna?

B. 9.85 dB

~~

E9A16 (C)

What is meant by the radiation resistance of an antenna?

C. The value of a resistance that would dissipate the same amount of power as that radiated from an antenna

~~

E9B Antenna patterns: E and H plane patterns; gain as a function of pattern; antenna design (computer modeling of antennas); Yagi antennas

E9B01 (C)

What determines the free-space polarization of an antenna?

C. The orientation of its electric field (E Field)

~~

E9B02 (B)

In the antenna radiation pattern shown in Figure E9-1, what is the 3-dB beamwidth?

B. 50 degrees

~~

E9B03 (B)

In the antenna radiation pattern shown in Figure E9-1, what is the front-to-back ratio?

B. 18 dB

~~

E9B04 (B)

In the antenna radiation pattern shown in Figure E9-1, what is the front-to-side ratio?

B. 14 dB

~~

E9B05 (D)

What may occur when a directional antenna is operated at different frequencies within the band for which it was designed?

D. The gain may exhibit significant variations

~~

E9B06 (B)

What usually occurs if a Yagi antenna is designed solely for maximum forward gain?

B. The front-to-back ratio decreases

~~

E9B07 (A)

If the boom of a Yagi antenna is lengthened and the elements are properly retuned, what usually occurs?

A. The gain increases

~~

E9B08 (C)

How does the total amount of radiation emitted by a directional (gain) antenna compare with the total amount of radiation emitted from an isotropic antenna, assuming each is driven by the same amount of power?

C. There is no difference between the two antennas

~~

E9B09 (A)

How can the approximate beamwidth of a directional antenna be determined?

A. Note the two points where the signal strength of the antenna is 3 dB less than maximum and compute the angular difference

~~

E9B10 (B)

What type of computer program technique is commonly used for modeling antennas?

B. Method of Moments

~~

E9B11 (A)

What is the principle of a Method of Moments analysis?

A. A wire is modeled as a series of segments, each having a distinct value of current

~~

E9B12 (C)

What is a disadvantage of decreasing the number of wire segments in an antenna model below the guideline of 10 segments per half-wavelength?

C. The computed feed-point impedance may be incorrect

~~

E9B13 (C)

Which of the following is a disadvantage of NEC-based antenna modeling programs?

C. Computing time increases as the number of wire segments is increased

~~

E9B14 (B)

What does the abbreviation NEC stand for when applied to antenna modeling programs?

B. Numerical Electromagnetics Code

~~

E9B15 (D)

What type of information can be obtained by submitting the details of a proposed new antenna to a modeling program?

A. SWR vs. frequency charts

B. Polar plots of the far-field elevation and azimuth patterns

C. Antenna gain

D. All of these answers are correct

~~

E9C Wire and phased vertical antennas: beverage antennas; terminated and resonant rhombic antennas; elevation above real ground; ground effects as related to polarization; take-off angles

E9C01 (D)

What is the radiation pattern of two 1/4-wavelength vertical antennas spaced 1/2-wavelength apart and fed 180 degrees out of phase?

D. A figure-8 oriented along the axis of the array

~~

E9C02 (A)

What is the radiation pattern of two 1/4-wavelength vertical antennas spaced 1/4-wavelength apart and fed 90 degrees out of phase?

A. A cardioid

~~

E9C03 (C)

What is the radiation pattern of two 1/4-wavelength vertical antennas spaced 1/2-wavelength apart and fed in phase?

C. A Figure-8 broadside to the axis of the array

~~

E9C04 (B)

Which of the following describes a basic rhombic antenna?

B. Bidirectional; four-sided, each side one or more wavelengths long; open at the end opposite the transmission line connection

E9C05 (A)

What are the main advantages of a terminated rhombic antenna?

A. Wide frequency range, high gain and high front-to-back ratio

~~

E9C06 (C)

What are the disadvantages of a terminated rhombic antenna for the HF bands?

C. The antenna requires a large physical area and 4 separate supports

~~

E9C07 (B)

What is the effect of a terminating resistor on a rhombic antenna?

B. It changes the radiation pattern from bidirectional to unidirectional

~~

E9C08 (A)

What type of antenna pattern over real ground is shown in Figure E9-2?

A. Elevation

~~

E9C09 (C)

What is the elevation angle of peak response in the antenna radiation pattern shown in Figure E9-2?

C. 7.5 degrees

~~

E9C10 (B)

What is the front-to-back ratio of the radiation pattern shown in Figure E9-2?

B. 28 dB

~~

E9C11 (A)

How many elevation lobes appear in the forward direction of the antenna radiation pattern shown in Figure E9-2?

A. 4

~~

E9C12 (D)

How is the far-field elevation pattern of a vertically polarized antenna affected by being mounted over seawater versus rocky ground?

D. The low-angle radiation increases

~~

E9C13 (D)

When constructing a Beverage antenna, which of the following factors should be included in the design to achieve good performance at the desired frequency?

D. It should be one or more wavelengths long

E9C14 (B)

How would the electric field be oriented for a Yagi with three elements mounted parallel to the ground?

B. Horizontally

~~

E9C15 (A)

What strongly affects the shape of the far-field, low-angle elevation pattern of a vertically polarized antenna?

A. The conductivity and dielectric constant of the soil in the area of the antenna

~~

***** E9C16 This question has been removed by the QPC

E9C17 (C)

What is the main effect of placing a vertical antenna over an imperfect ground?

C. It reduces low-angle radiation

~~

E9D Directional antennas: gain; satellite antennas; antenna beamwidth; losses; SWR bandwidth; antenna efficiency; shortened and mobile antennas; grounding

E9D01 (C)

How does the gain of a parabolic dish antenna change when the operating frequency is doubled?

C. Gain increases 6 dB

~~

E9D02 (C)

What is one way to produce circular polarization when using linearly polarized antennas?

C. Arrange two Yagis perpendicular to each other with the driven elements at the same point on the boom and fed 90 degrees out of phase

~~

E9D03 (D)

How does the beamwidth of an antenna vary as the gain is increased?

D. It decreases

~~

E9D04 (A)

Why is it desirable for a ground-mounted satellite communications antenna system to be able to move in both azimuth and elevation?

A. In order to track the satellite as it orbits the earth

~~

E9D05 (A)

For a shortened vertical antenna, where should a loading coil be placed to minimize losses and produce the most effective performance?

A. Near the center of the vertical radiator

~~

E9D06 (C)

Why should an HF mobile antenna loading coil have a high ratio of reactance to resistance?

C. To minimize losses

~~

E9D07 (A)

What is a disadvantage of using a multiband trapped antenna?

A. It might radiate harmonics

~~

E9D08 (B)

What happens to the bandwidth of an antenna as it is shortened through the use of loading coils?

B. It is decreased

~~

E9D09 (D)

What is an advantage of using top loading in a shortened HF vertical antenna?

D. Improved radiation efficiency

~~

E9D10 (A)

What is the approximate feed-point impedance at the center of a folded dipole antenna?

A. 300 ohms

~~

E9D11 (D)

Why is a loading coil often used with an HF mobile antenna?

D. To cancel capacitive reactance

~~

E9D12 (D)

What is an advantage of using a trapped antenna?

D. It may be used for multi-band operation

~~

E9D13 (B)

What happens at the base feed-point of a fixed-length HF mobile antenna as the frequency of operation is lowered?

B. The resistance decreases and the capacitive reactance increases

~~

E9D14(B)

Which of the following types of conductor would be best for minimizing losses in a station's RF ground system?

B. A thin, flat copper strap several inches wide

~~

E9D15 (C)

Which of these choices would provide the best RF ground for your station?

C. A connection to 3 or 4 interconnected ground rods driven into the Earth

~~

E9E Matching: matching antennas to feed lines; power dividers

E9E01 (B)

What system matches a high-impedance transmission line to a lower impedance antenna by connecting the line to the driven element in two places spaced a fraction of a wavelength each side of element center?

B. The delta matching system

~~

E9E02 (A)

What is the name of an antenna matching system that matches an unbalanced feed line to an antenna by feeding the driven element both at the center of the element and at a fraction of a wavelength to one side of center?

A. The gamma match

~~

E9E03 (D)

What is the name of the matching system that uses a short perpendicular section of transmission line connected to the feed line near the antenna?

D. The stub match

~~

E9E04 (B)

What is the purpose of the series capacitor in a gamma-type antenna matching network?

B. To compensate for the inductive reactance of the matching network

~~

E9E05 (A)

How must the driven element in a 3-element Yagi be tuned to use a hairpin matching system?

A. The driven element reactance must be capacitive

~~

E9E06 (C)

What is the equivalent lumped-constant network for a hairpin matching system on a 3-element Yagi?

C. L network

E9E07 (B)

What parameter best describes the interactions at the load end of a mismatched transmission line?

B. Reflection coefficient

~~

E9E08 (D)

Which of the following measurements describes a mismatched transmission line?

D. An SWR greater than 1:1

~~

E9E09 (C)

Which of these matching systems is an effective method of connecting a 50-ohm coaxial cable feed-line to a grounded tower so it can be used as a vertical antenna?

C. Gamma match

~~

E9E10 (C)

Which of these choices is an effective way to match an antenna with a 100-ohm terminal impedance to a 50-ohm coaxial cable feed-line?

C. Insert a 1/4-wavelength piece of 75-ohm coaxial cable transmission line in series between the antenna terminals and the 50-ohm feed cable

~~

E9E11 (B)

What is an effective way of matching a feed-line to a VHF or UHF antenna when the impedances of both the antenna and feed-line are unknown?

B. Use the "universal stub" matching technique

~~

E9E12 (A)

What is the primary purpose of a "phasing line" when used with an antenna having multiple driven elements?

A. It ensures that each driven element operates in concert with the others to create the desired antenna pattern

~~

E9E13 (C)

What is the purpose of a "Wilkinson divider"?

C. It divides power equally among multiple loads while preventing changes in one load from disturbing power flow to the others

~~

E9F Transmission lines: characteristics of open and shorted feed lines: 1/8 wavelength; 1/4 wavelength; 1/2 wavelength; feed lines: coax versus open-wire; velocity factor; electrical length; transformation characteristics of line terminated in impedance not equal to characteristic impedance

E9F01 (D)

What is the velocity factor of a transmission line?

D. The velocity of the wave in the transmission line divided by the velocity of light in a vacuum

~~

E9F02 (C)

What determines the velocity factor in a transmission line?

C. Dielectric materials used in the line

~~

E9F03 (D)

Why is the physical length of a coaxial cable transmission line shorter than its electrical length?

D. Electrical signals move more slowly in a coaxial cable than in air

~~

E9F04 (B)

What is the typical velocity factor for a coaxial cable with solid polyethylene dielectric?

B. 0.66

~~

E9F05 (C) (was E9E10)

What is the physical length of a coaxial transmission line that is electrically one-quarter wavelength long at 14.1 MHz? (Assume a velocity factor of 0.66.)

C. 3.5 meters

~~

E9F06 (C)

What is the physical length of a parallel conductor feed line that is electrically one-half wavelength long at 14.10 MHz? (Assume a velocity factor of 0.95.)

C. 10 meters

~~

E9F07 (A)

What characteristic will 450-ohm ladder line have at 50 MHz, as compared to 0.195-inch-diameter coaxial cable (such as RG-58)?

A. Lower loss

~~

E9F08 (A)

What is the term for the ratio of the actual speed at which a signal travels through a transmission line to the speed of light in a vacuum?

A. Velocity factor

~~

E9F09 (B)

What would be the physical length of a typical coaxial transmission line that is electrically one-quarter wavelength long at 7.2 MHz? (Assume a velocity factor of 0.66)

B. 6.9 meters

~~

E9F10 (C)

What kind of impedance does a 1/8-wavelength transmission line present to a generator when the line is shorted at the far end?

C. An inductive reactance

~~

E9F11 (C)

What kind of impedance does a 1/8-wavelength transmission line present to a generator when the line is open at the far end?

C. A capacitive reactance

~~

E9F12 (B)

What kind of impedance does a 1/4-wavelength transmission line present to a generator when the line is open at the far end?

B. A very low impedance

~~

E9F13 (A)

What kind of impedance does a 1/4-wavelength transmission line present to a generator when the line is shorted at the far end?

A. A very high impedance

~~

E9F14 (B)

What kind of impedance does a 1/2-wavelength transmission line present to a generator when the line is shorted at the far end?

B. A very low impedance

~~

E9F15 (A)

What kind of impedance does a 1/2-wavelength transmission line present to a generator when the line is open at the far end?

A. A very high impedance

~~

E9F16 (D)

What is the primary difference between foam-dielectric coaxial cable as opposed to solid-dielectric cable, assuming all other parameters are the same?

- A. Reduced safe operating voltage limits
- B. Reduced losses per unit of length
- C. Higher velocity factor
- D. All of these answers are correct

~~

E9G The Smith chart

E9G01 (A)

Which of the following can be calculated using a Smith chart?

- A. Impedance along transmission lines

~~

E9G02 (B)

What type of coordinate system is used in a Smith chart?

- B. Resistance circles and reactance arcs

~~

E9G03 (C)

Which of the following is often determined using a Smith chart?

- C. Impedance and SWR values in transmission lines

~~

E9G04 (C)

What are the two families of circles and arcs that make up a Smith chart?

- C. Resistance and reactance

~~

E9G05 (A)

What type of chart is shown in Figure E9-3?

- A. Smith chart

~~

E9G06 (B)

On the Smith chart shown in Figure E9-3, what is the name for the large outer circle on which the reactance arcs terminate?

- B. Reactance axis

~~

E9G07 (D)

On the Smith chart shown in Figure E9-3, what is the only straight line shown?

- D. The resistance axis

~~

E9G08 (C)

What is the process of normalization with regard to a Smith chart?

C. Reassigning impedance values with regard to the prime center

~~

E9G09 (A)

What third family of circles is often added to a Smith chart during the process of solving problems?

A. Standing-wave ratio circles

~~

E9G10 (D)

What do the arcs on a Smith chart represent?

D. Points with constant reactance

~~

E9G11 (B)

How are the wavelength scales on a Smith chart calibrated?

B. In fractions of transmission line electrical wavelength

~~

E9H Effective radiated power; system gains and losses; radio direction finding antennas

E9H01 (D)

What is the effective radiated power of a repeater station with 150 watts transmitter power output, 2-dB feed line loss, 2.2-dB duplexer loss and 7-dBd antenna gain?

D. 286 watts

~~

E9H02 (A)

What is the effective radiated power of a repeater station with 200 watts transmitter power output, 4-dB feed line loss, 3.2-dB duplexer loss, 0.8-dB circulator loss and 10-dBd antenna gain?

A. 317 watts

~~

E9H03 (B)

What is the effective radiated power of a repeater station with 200 watts transmitter power output, 2-dB feed line loss, 2.8-dB duplexer loss, 1.2-dB circulator loss and 7-dBd antenna gain?

B. 252 watts

~~

E9H04 (C)

What term describes station output (including the transmitter, antenna and everything in between), when considering transmitter power and system gains and losses?

C. Effective radiated power

~~

E9H05 (A)

What is the main drawback of a wire-loop antenna for direction finding?

A. It has a bidirectional pattern

~~

E9H06 (C)

What is the triangulation method of direction finding?

C. Antenna headings from several different receiving stations are used to locate the signal source

~~

E9H07 (D)

Why is an RF attenuator desirable in a receiver used for direction finding?

D. It prevents receiver overload from extremely strong signals

~~

E9H08 (A)

What is the function of a sense antenna?

A. It modifies the pattern of a DF antenna array to provide a null in one direction

~~

E9H09 (C)

What is a receiving loop antenna?

C. One or more turns of wire wound in the shape of a large open coil

~~

E9H10 (D)

How can the output voltage of a receiving loop antenna be increased?

D. By increasing either the number of wire turns in the loop or the area of the loop structure

~~

E9H11 (B)

Why is an antenna with a cardioid pattern desirable for a direction-finding system?

B. The response characteristics of the cardioid pattern can assist in determining the direction of the desired station

~~

E9H12 (B)

What is an advantage of using a shielded loop antenna for direction finding?

B. It is electro-statically balanced against ground, giving better nulls

~~

SUBELEMENT E0 -- SAFETY [1 exam question -- 1 group]

EOA Safety: amateur radio safety practices; RF radiation hazards; hazardous materials

EOA01 (C)

What, if any, are the differences between the radiation produced by radioactive materials and the electromagnetic energy radiated by an antenna?

C. RF radiation does not have sufficient energy to break apart atoms and molecules; radiation from radioactive sources does

~~

EOA02 (B)

When evaluating exposure levels from your station at a neighbor's home, what must you do?

B. Make sure signals from your station are less than the uncontrolled MPE limits

~~

EOA03 (D)

Which of the following would be a practical way to estimate whether the RF fields produced by an amateur radio station are within permissible MPE limits?

D. Use a computer-based antenna modeling program to calculate field strength at accessible locations

~~

EOA04 (C)

When evaluating a site with multiple transmitters operating at the same time, the operators and licensees of which transmitters are responsible for mitigating over-exposure situations?

C. Each transmitter that produces 5% or more of its maximum permissible exposure limit at accessible locations

~~

EOA05 (B)

What is one of the potential hazards of using microwaves in the amateur radio bands?

B. The high gain antennas commonly used can result in high exposure levels

~~

EOA06 (D)

Why are there separate electric (E) and magnetic (H) field MPE limits?

- A. The body reacts to electromagnetic radiation from both the E and H fields
- B. Ground reflections and scattering make the field impedance vary with location
- C. E field and H field radiation intensity peaks can occur at different locations
- D. All of these answers are correct

~~

EOA07 (D)

What is the "far-field" zone of an antenna?

- A. The area of the ionosphere where radiated power is not refracted
- B. The area where radiated power dissipates over a specified time period
- C. The area where radiated field strengths are obstructed by objects of reflection
- D. The area where the shape of the antenna pattern is independent of distance

~~

EOA08 (C)

What does SAR measure?

C. The rate at which RF energy is absorbed by the body

~~

EOA09 (C)

Which insulating material commonly used as a thermal conductor for some types of electronic devices is extremely toxic if broken or crushed and the particles are accidentally inhaled?

C. Beryllium Oxide

~~

EOA10 (A)

What material found in some electronic components such as high-voltage capacitors and transformers is considered toxic?

A. Polychlorinated biphenyls

~~

EOA11 (C)

Which of these items might be a significant hazard when operating a klystron or cavity magnetron transmitter?

C. Injury from radiation leaks that exceed the MPE limits

~~

end of question pool

User note:

The graphics required for certain questions in sections E5, E6, E7, and E9 are included on the following pages

FIGURE E0-2

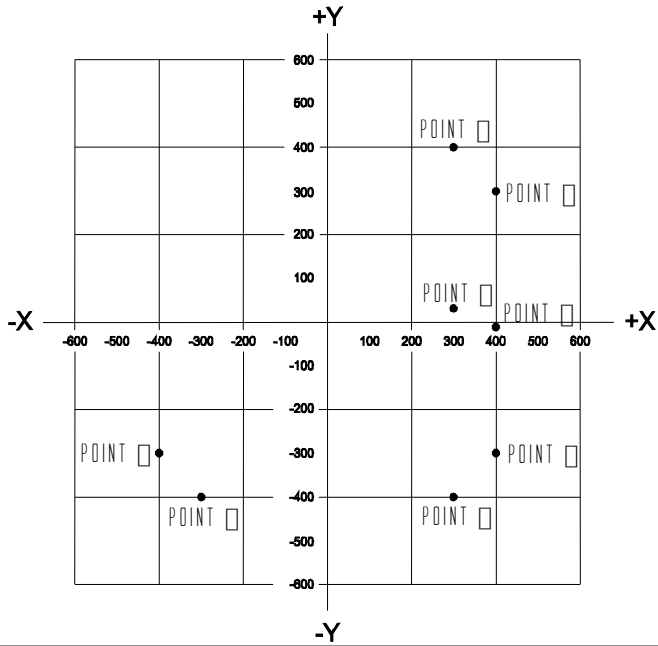

FIGURE E7-1

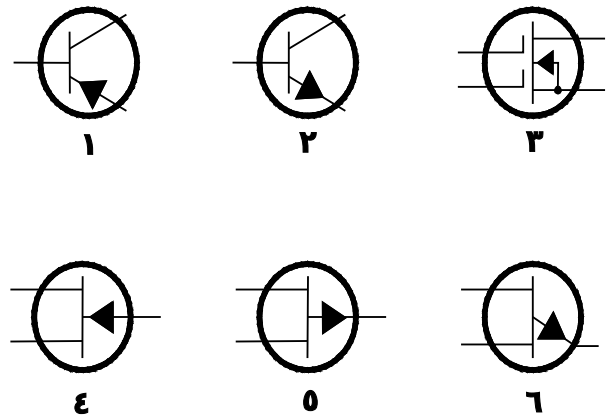

FIGURE E6-2

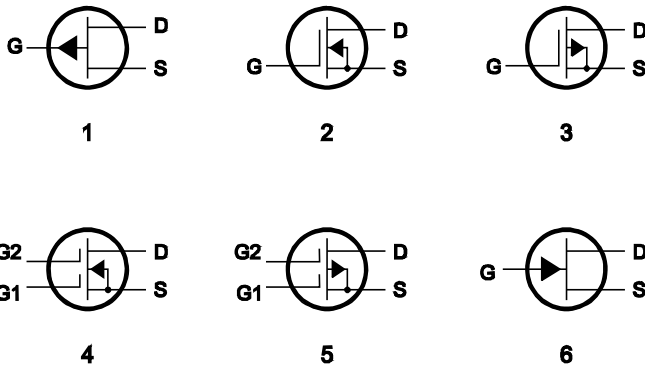

FIGURE E6-3

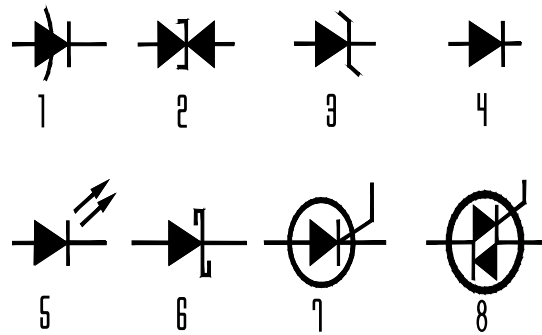

FIGURE E6-5

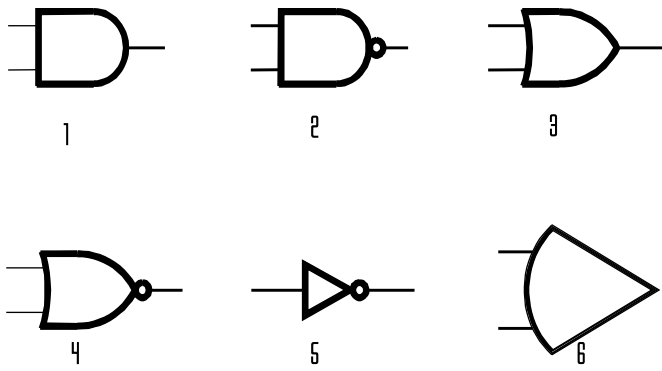

FIGURE E7-1

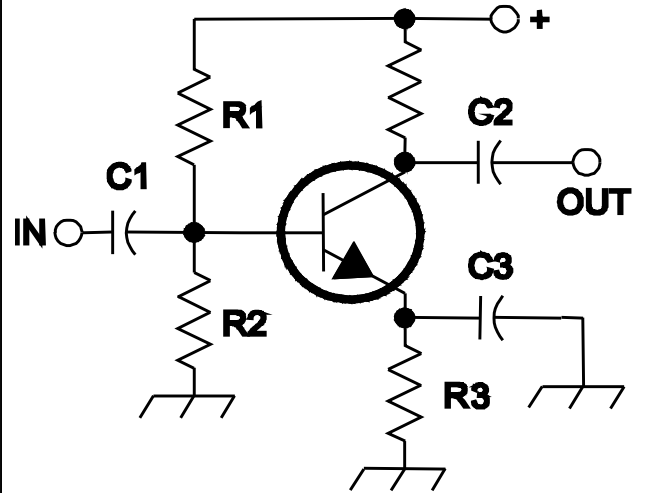

FIGURE E7-2

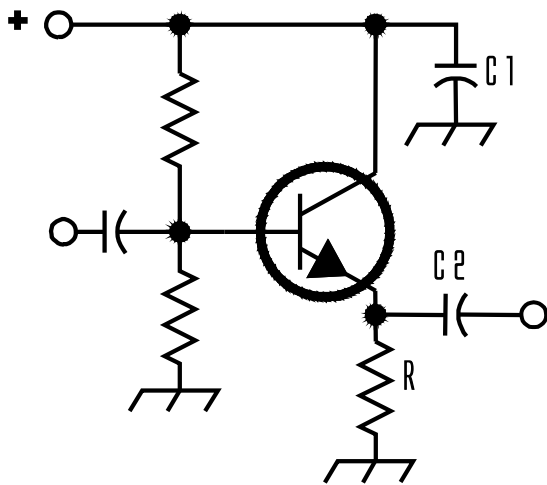

FIGURE E7-3

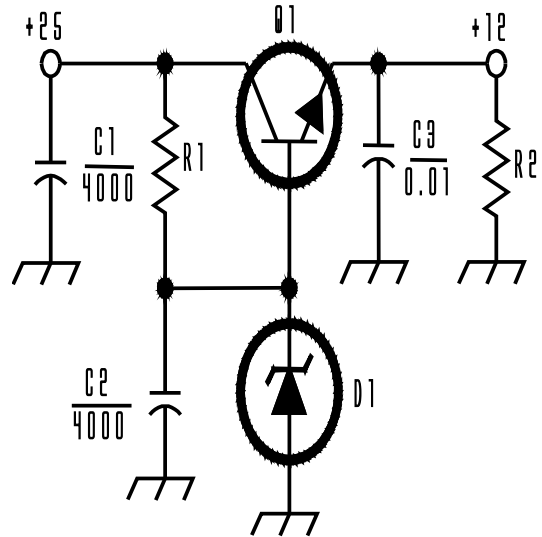

FIGURE E7-4

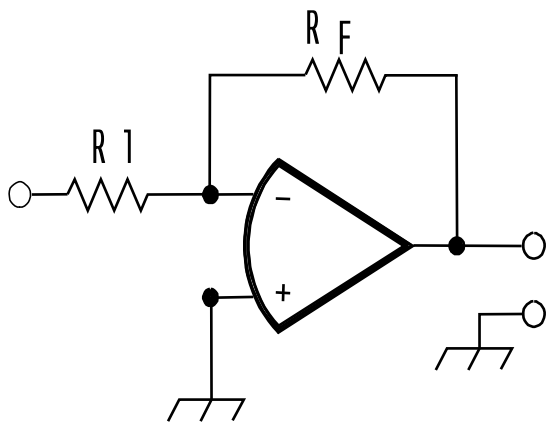

FIGURE E9-1

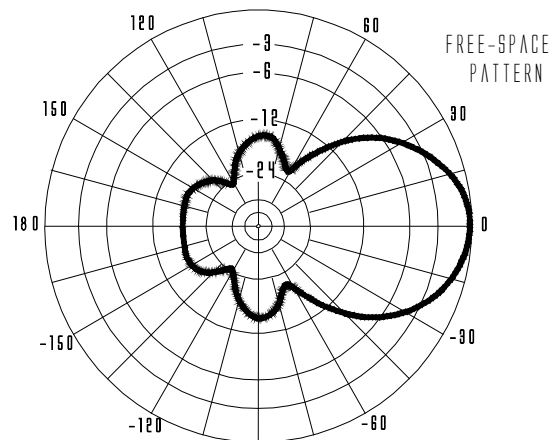

FIGURE E 9-2

OVERREALG ROUN D

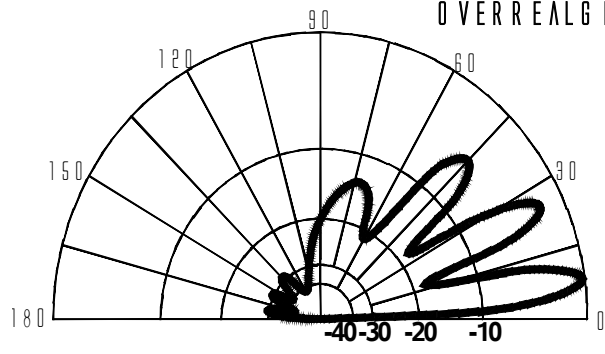

FIGURE E 9-3

